

# ENSTO

## Ensto One



**ENG** Installation Manual



CE



RAK132\_ENG  
6.4.2021  
© 2020 Ensto

# Contents

|   |    |
|---|----|
| 1. Safety instructions.....   | 3  |
| 2. Delivery contents.....   | 3  |
| 3. Charger features.....  | 4  |
| 4. Mounting instructions.....   | 5  |
| 4.1. Before installation.....   | 5  |
| 4.2. Cable entries.....   | 6  |
| 4.3. Wall mounting.....   | 8  |
| 5. Electrical connections.....  | 10 |
| 5.1. Power supply.....  | 10 |
| 5.2. Data connection.....   | 12 |
| 6. Commissioning the charger.....   | 12 |
| 6.1. Change the operating mode to "Authorized".....   | 13 |
| 7. Technical information.....   | 14 |
| 8. Code key.....  | 16 |
| 9. Installation / Commissioning checklist.....  | 17 |
| 10. Maintenance / Preventive Maintenance Instructions.....                                  | 18 |
| 11. Testing instructions for the electric protective device.....                            | 18 |
| 12. EVH161-ACRM0 / EVH321-ACRM0 internal circuit example.....                               | 19 |
| 13. EVH161-A2RM0 / EVH321-A2RM0 / EVH161-ASRM0 / EVH321-ASRM0 internal circuit example..... | 20 |
| 14. EVH161-A2RMD internal circuit example.....  | 21 |
| 15. EVH163-A2RM0 / EVH323-A2RM0 / EVH163-ASRM0 / EVH323-ASRM0 internal circuit example..... | 22 |
| 16. Dimension drawing.....  | 23 |
| 17. Troubleshooting.....  | 23 |
| 18. Disposal.....   | 24 |
| 19. Warranty.....   | 24 |
| 20. Declaration of Conformity.....  | 24 |
| 21. Ensto Charger Control Application.....  | 25 |
| 21.1. Installing the application.....   | 25 |
| 21.2. Pairing the charger with your mobile device.....                                      | 26 |
| 21.3. Installer menu in the Ensto Charger Control Application.....                          | 27 |
| 21.3.1. Self test.....  | 27 |
| 21.3.2. Connection settings.....  | 28 |
| 21.3.3. Update device firmware.....   | 28 |
| 21.3.4. Maximum charging current.....   | 28 |
| 21.3.5. Connected phases.....   | 29 |
| 21.3.6. Phase rotation (only 3-phase chargers).....   | 29 |
| 21.3.7. Dynamic Load Management (DLM).....  | 29 |
| 21.3.8. Offline current.....  | 29 |
| 21.3.9. Eathing System.....   | 29 |
| 21.3.10. Overcurrent limit.....   | 29 |
| 21.4. Error messages.....   | 30 |

# Installation Manual

## 1. Safety instructions



### Electrically skilled person

- The installation must only be done by an electrician with the appropriate qualifications.
- Read this Installation Manual carefully before starting the installation work.
- Follow the instructions in this Installation Manual, and make sure that the installation complies with national safety regulations, installation methods and restrictions.
- The information provided in this Installation Manual in no way exempts the installer or user from responsibility to follow all applicable safety regulations.
- This Installation Manual is a part of the product and must be stored in a safe location so that it is available for future installation and service.



### WARNING

*Danger of electric shock! Risk of fire!*

- *Improper installation can cause personal injury and property damage.*
- *Do not switch on the power supply before the installation work is completed.*

## 2. Delivery contents

- EVH Charger
- Cable gland M32/M25 (depending on the model)
- Installation Manual in English, other languages please see [www.ensto.com](http://www.ensto.com).
- Multilingual User Guide

### 3. Charger features

Available features depend on the charger model.

#### EVH...-ACRM0

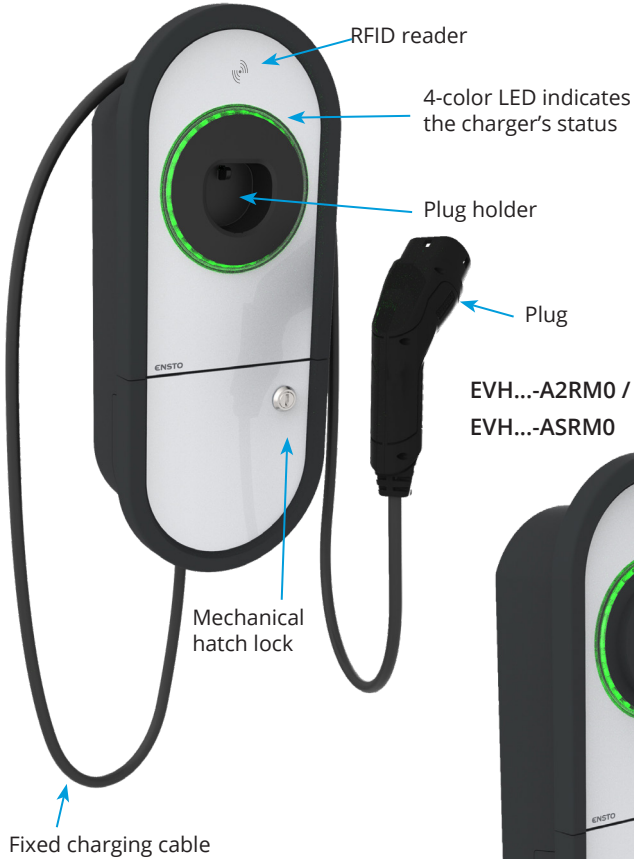

#### EVH...-A2RM0 / EVH161-A2RMD

#### EVH...-ASRM0

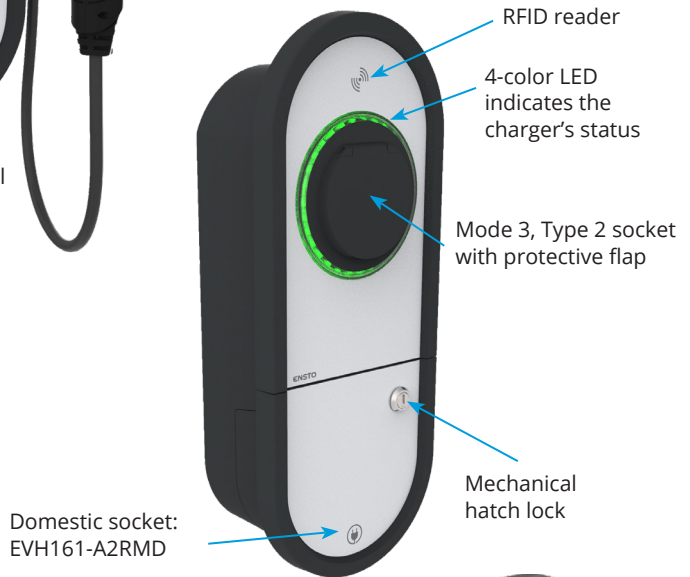

Separate charging cable, not included



## 4. Mounting instructions

### 4.1. Before installation

Remove the charger from its package. Do not scratch the surface of the charger after removal from the package.

When selecting installation site, take into account the following:

- The charger is suitable for indoor and outdoor use.
- In order to ensure the optimal charging performance, the charger should not be exposed to direct sunlight.
- The minimum space needed for operating and maintenance.

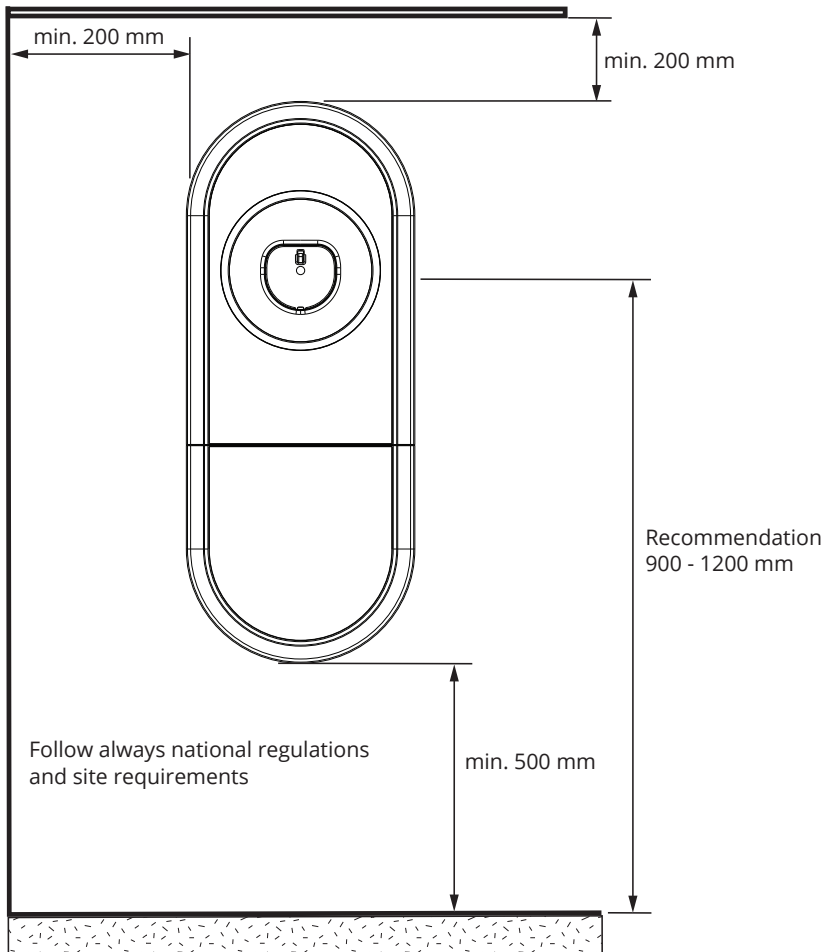

## 4.2. Cable entries

- Take the cable routing into consideration when planning the installation. The supply cable can be routed into the enclosure from the rear or bottom. Default cable routing is from the bottom.
- The M32 cable gland for the supply cable is pre-assembled on the bottom of the charger.
- If you need to open additional cable entries, you have to disassemble the charger.

### Installation steps when cable routing is from alternative cable entries

1. Disassemble the charger.

- 4** Remove the screws 5pcs.  
Remove the insert from the base.

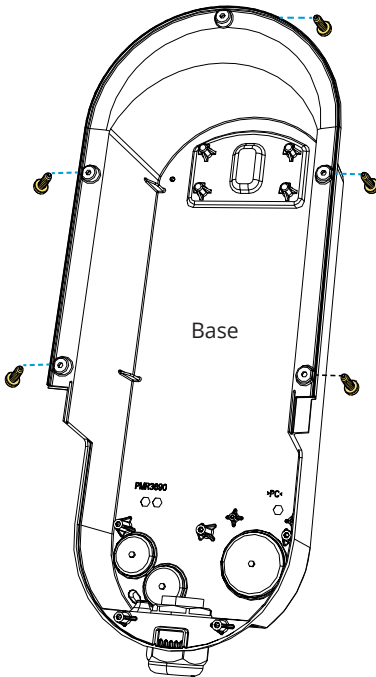

Unlock the hatch with a coin or suchlike.

**1**

- 2** Remove the screws 4pcs.  
Remove the installation box cover.

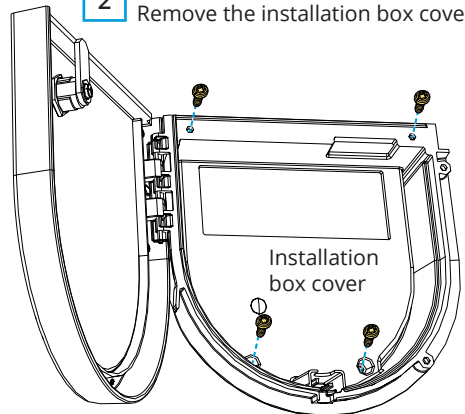

- 3** Remove the screws 2pcs.

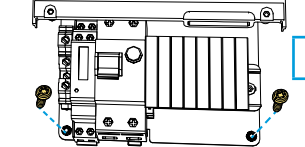

2. Open the needed cable entries with a step drill bit.
3. Prepare the cable entries with suitable accessories.
4. Remove the included cable gland from the bottom and close the cable entry with a cover plug, PMR1217.32B (accessory).
5. Assemble the base and insert.
6. Assemble also the installation box cover, if electrical cables are installed in a separate session.

1 x M25 / M32  
M32 cable gland for cable Ø 17-25mm  
pre-assembled

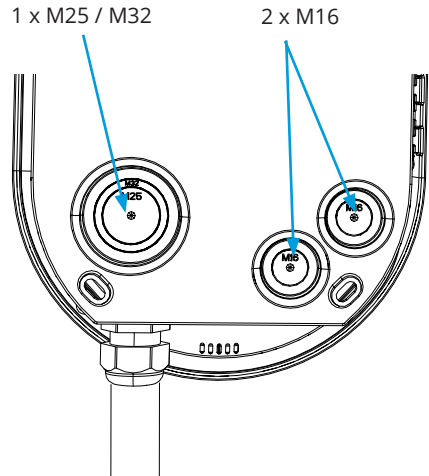
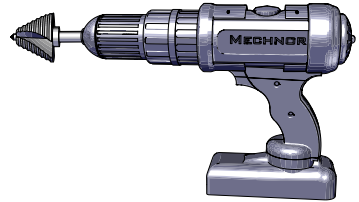
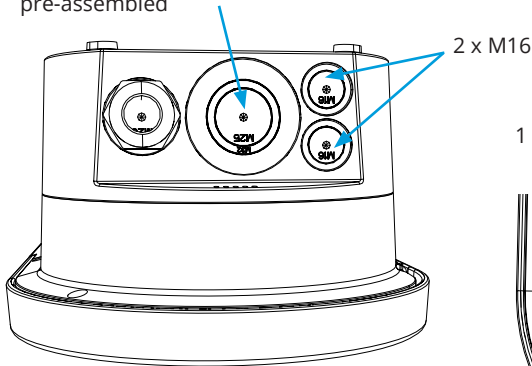

| Accessories    |                                       |                        |
|----------------|---------------------------------------|------------------------|
| Part number    | Description                           | Note                   |
| PMR1217.32B    | Black cover plug for M32 opening      |                        |
| KTM24.25/BLACK | M25 cable gland for cable Ø 10 - 16mm | EVH16...: included 1pc |
| PMR1219.3225B  | Black reduction nipple, M32 => M25    | EVH16...: included 1pc |
| RGM16B         | Membrane gasket for cable Ø 5 - 9mm   |                        |
| RMM25B         | Membrane gasket for cable Ø 8 - 17mm  |                        |
| RMM32B         | Membrane gasket for cable Ø 12 - 24mm |                        |

### 4.3. Wall mounting

- When selecting the installation location, make sure that the wall material is suitable and robust. The mounting surface should be flat and vertical.

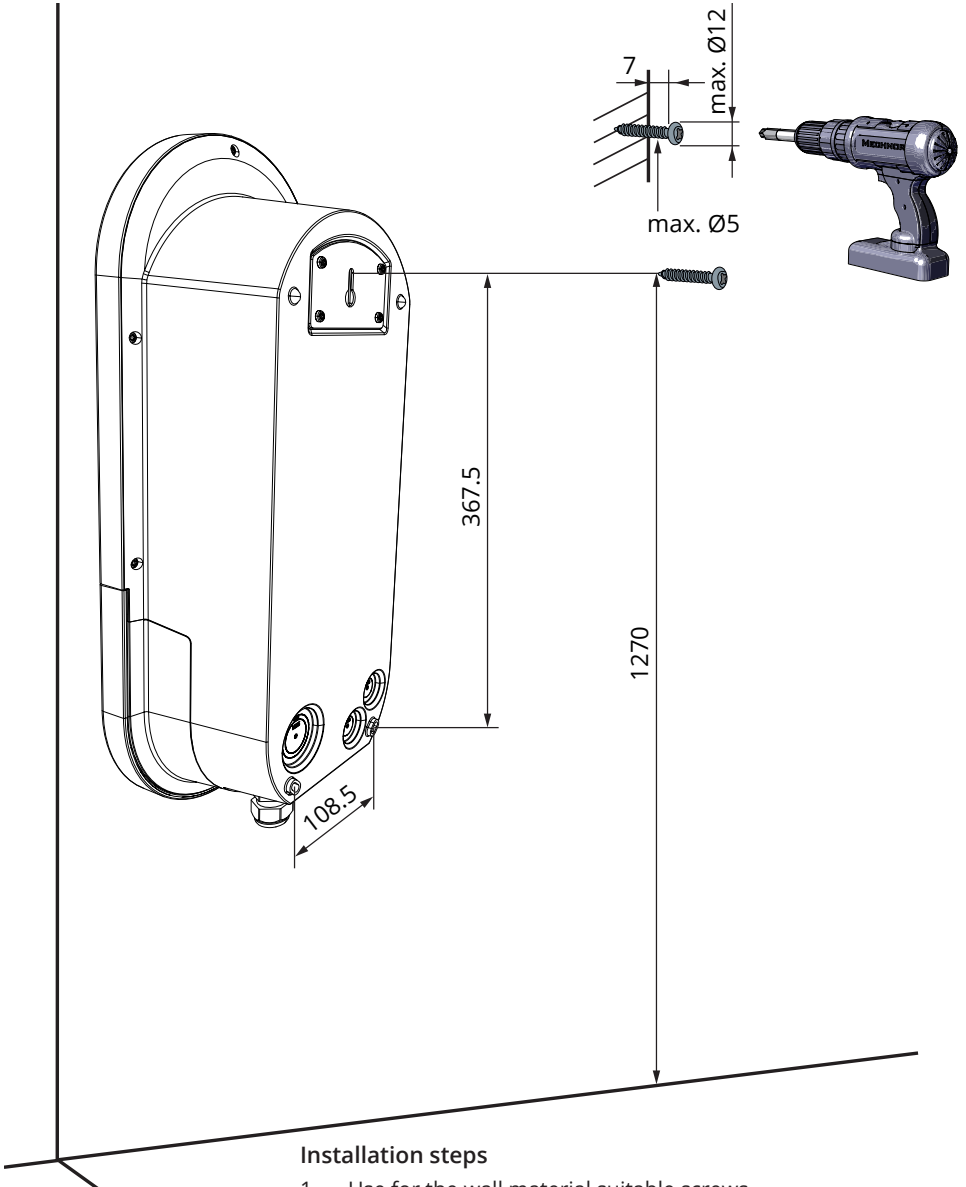

#### Installation steps

1. Use for the wall material suitable screws.
2. Fasten the upper screw 1270 mm measured from the ground surface. The plug holder will be at a height of 1200 mm.



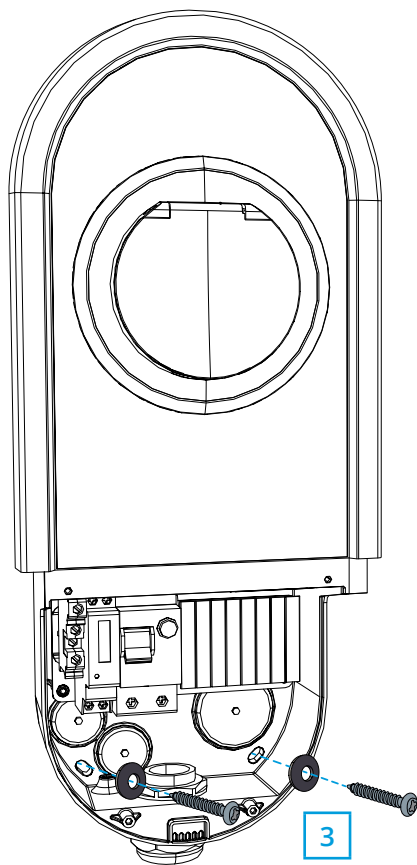

TX20  
Tightening torque 1,5 Nm

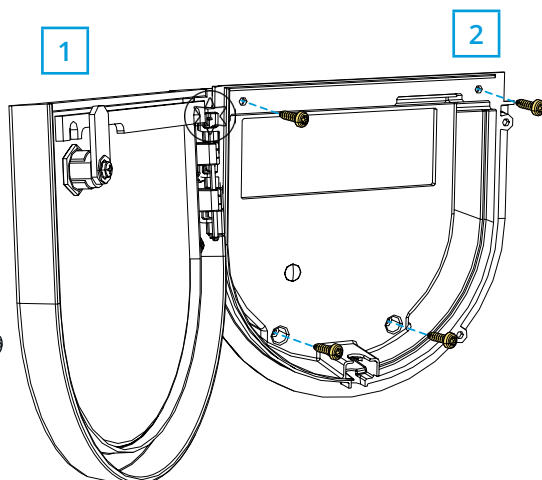

3. Open the installation box hatch by unlocking the hatch lock with a coin or suchlike [1].
4. Remove the entire installation box cover by unscrewing the fastening screws (4 pcs) [2].
5. Hang the charger on the screw you attached to the wall.
6. Secure the charger on wall with two washers and fastening screws (not included) [3].  
***EVB161-ACRMO / EVH321-ACRMO: Be careful not to damage the fixed charging cable!***
7. Pull the electrical cables approx. 150mm through the cable glands.
8. Cut the supply cable leads in suitable lengths. Leave the ground lead long enough so that if a fault occurs it is the last one that comes loose.
9. Strip the leads 11 mm and connect to the supply connectors.
10. Put the installation box cover back in right position and secure with the screws you removed.
11. Close the installation box hatch.

## 5. Electrical connections

The voltage and current ratings including cable sizes must comply with national regulations. The system dimensioning must be done by a qualified electrical designer.

*A combined device with residual current circuit breaker and over current protection (RCBO) is integrated.*

A label set of RCBO testing instructions is included in the delivery. Attach a language specific label on the installation box hatch.

### 5.1. Power supply



*The default setting for the earthing system is TN network.*

Do not connect Ensto One Apartment chargers to an IT network.

#### EVH161-ACRM0 / EVH321-ACRM0

- Fixed charging cable

#### EVH161-A2RM0 / EVH321-A2RM0

#### EVH161-ASRM0 / EVH321-ASRM0

- Separate charging cable

#### TN network

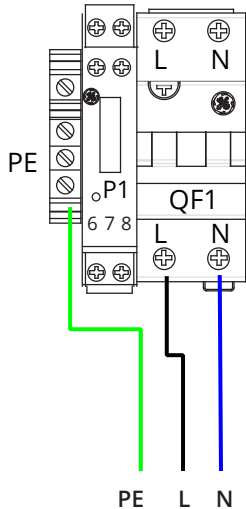

Supply  
Cu 2.5 - 10 mm<sup>2</sup>

## EVH161-A2RMD

- Separate charging cable
- Domestic socket

### TN network

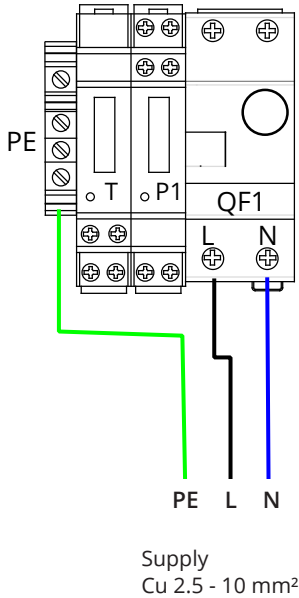

## EVH163-A2RMD0 / EVH323-A2RMD0

## EVH163-ASRMD0 / EVH323-ASRMD0

- Separate charging cable

Note! Connect these charger models to a 3-phase supply, otherwise the RCBO test button does not work.

### TN network

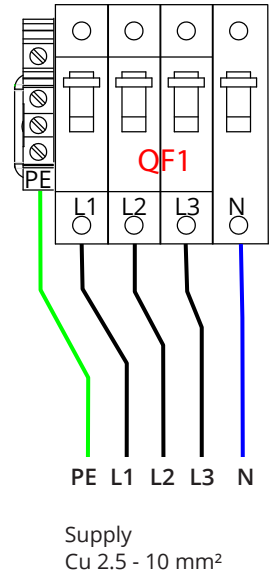

## 5.2. Data connection

Ensto One Apartment chargers has available Ethernet connectivity. The chargers can be connected to Ensto EV Manager based on ordered subscription and terms related. Please contact your local Ensto sales representative for more information.

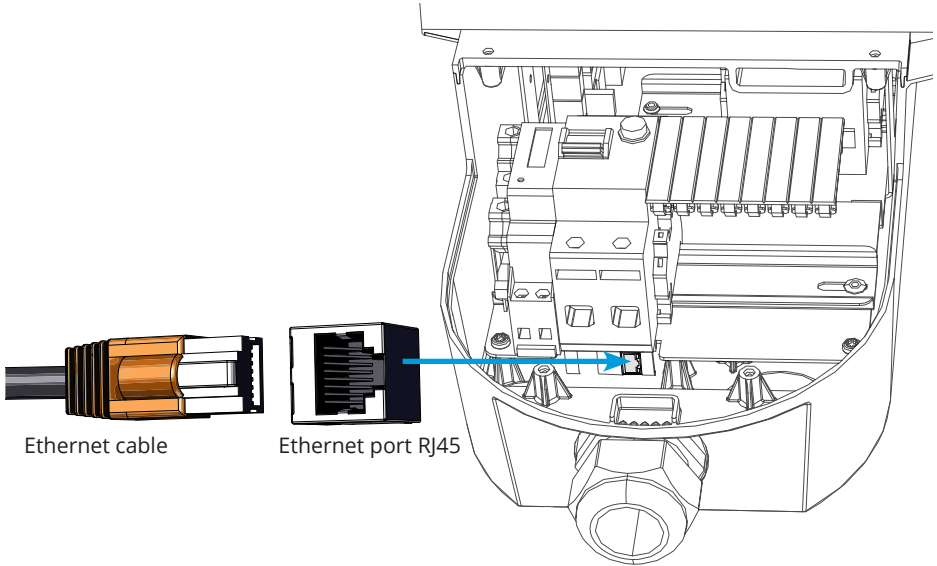

## 6. Commissioning the charger

The charger is ready to use after the installation is completed. The charger is in **“Free charging”** operating mode. You can configurate charger’s settings in EV Manager. Please see the EV Manager User Manual <https://ewiki.ensto.technology/display/CHWI/EV+Manager>.

You can also make changes to the settings with Ensto Charger Control Application. You can download the application from Google Play or App Store. Please see instructions in chapter **21. Ensto Charger Control Application** on pages 25 - 31.

## 6.1. Change the operating mode to "Authorized"

Change the operating mode to "**Authorized**" in EV Manager.

### Installation steps

1. Open your EV Manager in a web browser (Google Chrome or Firefox).
2. Select the charger you want to change to "**Authorized**" operating mode. Note! The charger must have connection to the internet.
3. Select "**Edit this charging station**".

Home / Charging stations / EVH200617849831311

**EDIT THIS CHARGING STATION**

#4 : EVH200617849831311

CHARGING GROUP:  
DLM Wall (Ensto)

CHARGING EVENTS  
0  
LAST 24 HOURS

CHARGING POINTS  
0  
LAST 24 HOURS

KWH CHARGED  
0  
LAST 24 HOURS

Charging points | Event feed | Statistics

EVH200617849831311 (Charging point #1)

Status: Available

No sockets data

RELEASE CABLE

START CHARGING

4. Select the tab "**Advanced settings**".

Home / Charging stations / EVH200617849831311 / Edit charging station

Edit charging station

CANCEL | SAVE CHANGES

Basic settings | Advanced settings | Charging points

5. Refresh configuration.
6. Change the value "**EVSE.FREECHARGIN**" from "**1**" to "**0**".
7. Save the changes.

## 7. Technical information

| Electrical Connections           | EVH161-ACRMO  | EVH321-ACRMO | EVH161-A2RMO<br>EVH161-ASRMO | EVH321-A2RMO<br>EVH321-ASRMO | EVH161-A2RMD |
|----------------------------------|---|--------------|------------------------------|------------------------------|--------------|
| Nominal supply voltage           | 1-ph, 230 VAC   |              |                              |                              |              |
| Nominal frequency                | AC 50 Hz  |              |                              |                              |              |
| Charging current max.            | 1x16 A  | 1x32 A       | 1x16 A                       | 1x32 A                       | 1x16 A       |
| Charging power max.              | 3600 W  | 7400 W       | 3600 W                       | 7400 W                       | 3600 W       |
| Supply connections and terminals | L, N, PE<br>Cu 2.5–10 mm <sup>2</sup><br>L and N tightening torque: 2 - 2.4 Nm / PE tightening torque: 2.5 - 3.0 Nm |              |                              |                              |              |

| Additional Electric Features | EVH161-A2RMD   |
|------------------------------|--|
| Domestic socket              | <ul style="list-style-type: none"> <li>Output current &lt; 10 A</li> <li>Electricity is not available if the charging cable is connected to the charger</li> </ul> |
| Analogue timer switch        | <ul style="list-style-type: none"> <li>24 hours timer</li> <li>2 hours fixed operating time</li> </ul>   |

| Electrical Connections           | EVH163-A2RMO<br>EVH163-ASRMO   | EVH323-A2RMO<br>EVH323-ASRMO |
|----------------------------------|--|------------------------------|
| Nominal supply voltage           | 3-ph, 400 VAC  |                              |
| Nominal frequency                | AC 50 Hz   |                              |
| Charging current max.            | 3x16 A   | 3x32 A                       |
| Charging power max.              | 11 000 W   | 22 000 W                     |
| Supply connections and terminals | L1, L2, L3, N, PE<br>Cu 2.5–10 mm <sup>2</sup><br>L and N tightening torque:<br>2 - 2.4 Nm<br>PE tightening torque:<br>2.5 - 3.0Nm |                              |

| Design and Mechanics  | EVH161-ACRM0  | EVH321-ACRM0 | EVH161-A2RM0<br>EVH163-A2RM0<br>EVH161-ASRM0<br>EVH163-ASRM0 | EVH321-A2RM0<br>EVH323-A2RM0<br>EVH321-ASRM0<br>EVH323-ASRM0 | EVH161-A2RMD |
|-----------------------|---|--------------|--|--|--------------|
| Material              | Polycarbonate   |              |  |  |              |
| Color                 | Frame: RAL7021 dark grey<br>Cover: Silver   |              |  |  |              |
| Installation box      | Mechanical hatch lock   |              |  |  |              |
| Weight                | 5 ... 8 kg  |              |  |  |              |
| Ingress Protection    | IP 54   |              |  |  |              |
| Impact Resistance     | IK10  |              |  |  |              |
| Operating temperature | -40 °C ... +50 °C<br>MID kWh meter: Below -25 °C the exact kWh measurement or correct reading of the display cannot be guaranteed. This will not affect the operation of the charger. |              |  |  |              |
| Mounting              | Wall / Ground   |              |  |  |              |

| User Interface             | EVH161-ACRM0  | EVH321-ACRM0 | EVH161-A2RM0<br>EVH163-A2RM0<br>EVH161-ASRM0<br>EVH163-ASRM0 | EVH321-A2RM0<br>EVH323-A2RM0<br>EVH321-ASRM0<br>EVH323-ASRM0 | EVH161-A2RMD           |
|----------------------------|---|--------------|--|--|------------------------|
| Connection to vehicle      | Fixed cable, length 5m  |              | Mode3, Type 2 socket *                                       |  | Mode3, Type 2 socket * |
| Charging status indication | 4-color LED:<br>Green = Ready / Blue = Charging / Red = Error / Yellow = Internal maintenance |              |  |  |                        |
| Use access                 | Free access<br>RFID (ISO/IEC 14443A, ISO/IEC 15693)<br>Mobile application                     |              |  |  |                        |
| Current measurement        | MID class kWh meter   |              |  |  |                        |

\*The charging cable is not included.

| Control and Communication | EVH161-ACRM0  | EVH321-ACRM0 | EVH161-A2RM0<br>EVH163-A2RM0<br>EVH161-ASRM0<br>EVH163-ASRM0 | EVH321-A2RM0<br>EVH323-A2RM0<br>EVH321-ASRM0<br>EVH323-ASRM0 | EVH161-A2RMD |
|---------------------------|---|--------------|--|--|--------------|
| Operation mode            | Standalone / Online   |              |  |  |              |
| Wireless                  | Bluetooth   |              |  |  |              |
| Wired                     | Ethernet  |              |  |  |              |
| Charging control system   | "Simplified control pilot" functionality, specified in EN IEC 61851-1:2019, Annex A.2.3 is not supported.<br>ZEReady 1.2b and EVReady 1.4b are not supported. |              |  |  |              |

## 8. Code key

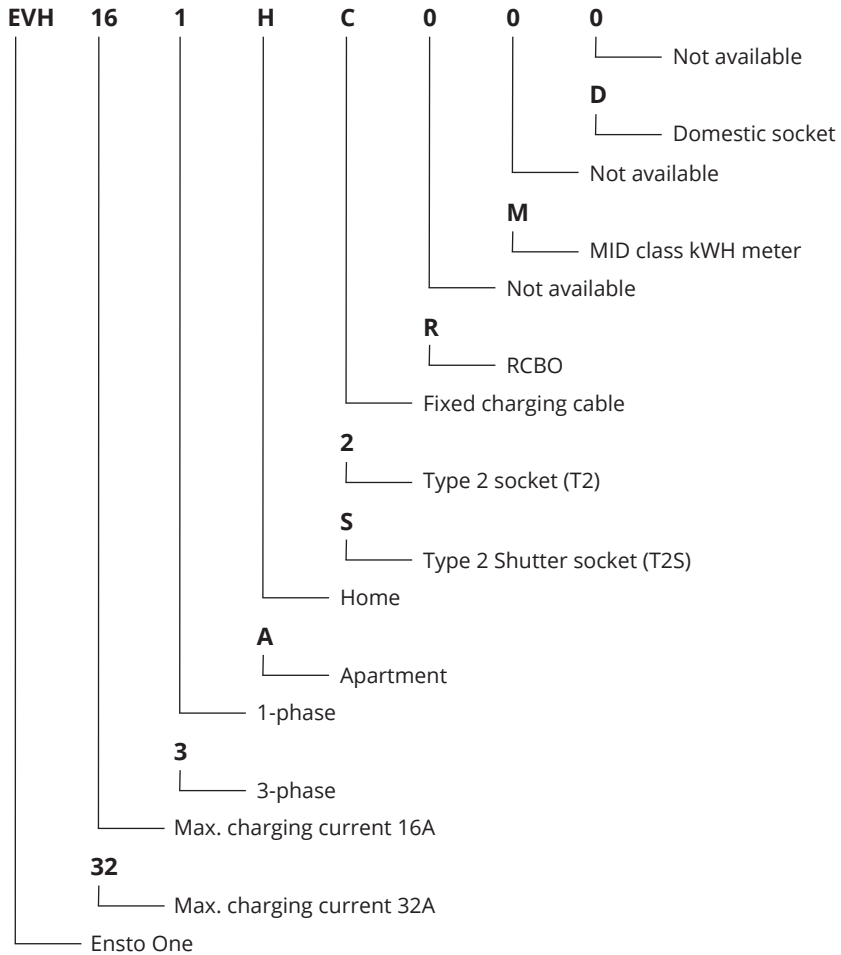



## 9. Installation / Commissioning checklist

### Introduction

Check the mechanical and electrical installation according this checklist in order to make sure that the charger is properly installed.

### Checking the Installation



*Go through the visual, mechanical and electrical installation when the charger is un-powered.*

| CATEGORY                | X | ITEM  |
|-------------------------|---|---|
| Overall look            |   | You have received the ordered material.   |
|                         |   | You do not see any scratches or damages.  |
| Mechanical installation |   | The charger is fixed properly on the installation site.   |
| Electrical installation |   | Charger's power supply capacity meets electrical planning (cable size, protective devices...).  |
|                         |   | Review local electrical design plan.  |
|                         |   | The PE-cable screw is tight.  |
|                         |   | The power supply conductors (L1, L2, L3, N and PE) are properly connected.  |
|                         |   | The insulation of power supply cable and conductors (L1, L2, L3, N and PE) is intact.   |
| Operational check       |   | The voltage between PE and N is less than 10 V  |
|                         |   | The PE conductor resistance is less than 3 $\Omega$   |
|                         |   | All the LED states / color (green, blue, red) are functioning. <ul style="list-style-type: none"><li>• Use a car simulator.</li><li>• Create fail and charge.</li><li>• Red at bootup, green at idle and blue while charging.</li></ul> |
| Ready for use           |   | Test the functionality of the electric protective device.   |
|                         |   | Correct software is in use.   |
|                         |   | Correct operating mode is set.  |
|                         |   | Test the data communication (Ethernet), if it is in use.  |

## 10. Maintenance / Preventive Maintenance Instructions

Do maintenance actions once a year or as needed.

With well-done maintenance you can ensure a long lifetime of the charger and keep the warranty valid.



### **WARNING**

***Danger of electric shock! Risk of fire!***

***Disconnect power before working inside the device or removing any components.***

| X | MAINTENANCE ACTION  |
|---|---|
|   | Clean possible dirt and dust from the charger surface. Wipe carefully with a damp cloth.  |
|   | Retighten all screws on electric components.  |
|   | Examine the socket for burn or damaged parts. If necessary, replace the socket (socket cost is not under warranty).   |
|   | Examine the charging cable for wear out and mechanical damage. If necessary, replace the charging cable.  |
|   | Examine the sealings for wear out. If necessary, replace the sealings.  |
|   | All the LED states / color (green, blue, red) are functioning. <ul style="list-style-type: none"><li>• Use a car simulator.</li><li>• Create fail and charge.</li><li>• Red at bootup, green at idle and blue while charging.</li></ul> |
|   | Make sure the PE-cable screw is tight.  |
|   | Test that the voltage between PE and N is less than 10 V.   |
|   | Test that the PE conductor resistance is less than 3 $\Omega$ .   |
|   | The internal maintenance of the charger, if necessary. The maintenance takes at least 10 minutes.<br><b><i>Do not switch off the power or use the charger during the maintenance.</i></b>   |
|   | Restart the charger from QF1. Make sure that it will restart properly.  |
|   | Test the electric protective device. Comply local requirements for testing interval, but test the device at least once every six months.  |

## 11. Testing instructions for the electric protective device

- The combined device with residual current circuit breaker and over current protection (RCBO) is located in the installation box.
- Open the installation box hatch.
- Press the **TEST** button.
- The rocker turns to the **0** position.
- Turn the rocker back to the **I** position.
- If a fault occurs, contact an electrician.

## 12. EVH161-ACRM0 / EVH321-ACRM0 internal circuit example

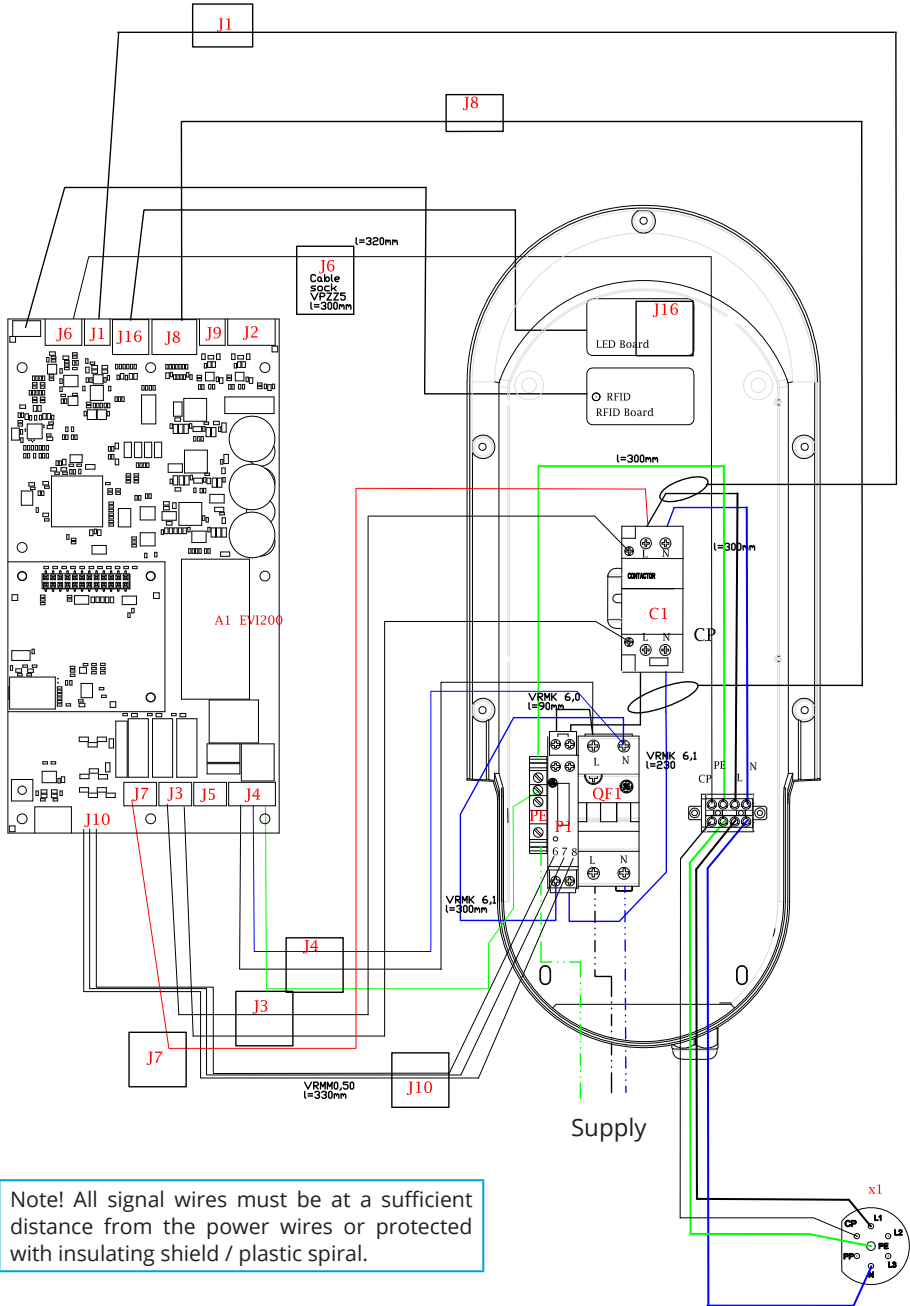

Note! All signal wires must be at a sufficient distance from the power wires or protected with insulating shield / plastic spiral.

### 13. EVH161-A2RM0 / EVH321-A2RM0 / EVH161-ASRM0 / EVH321-ASRM0 internal circuit example

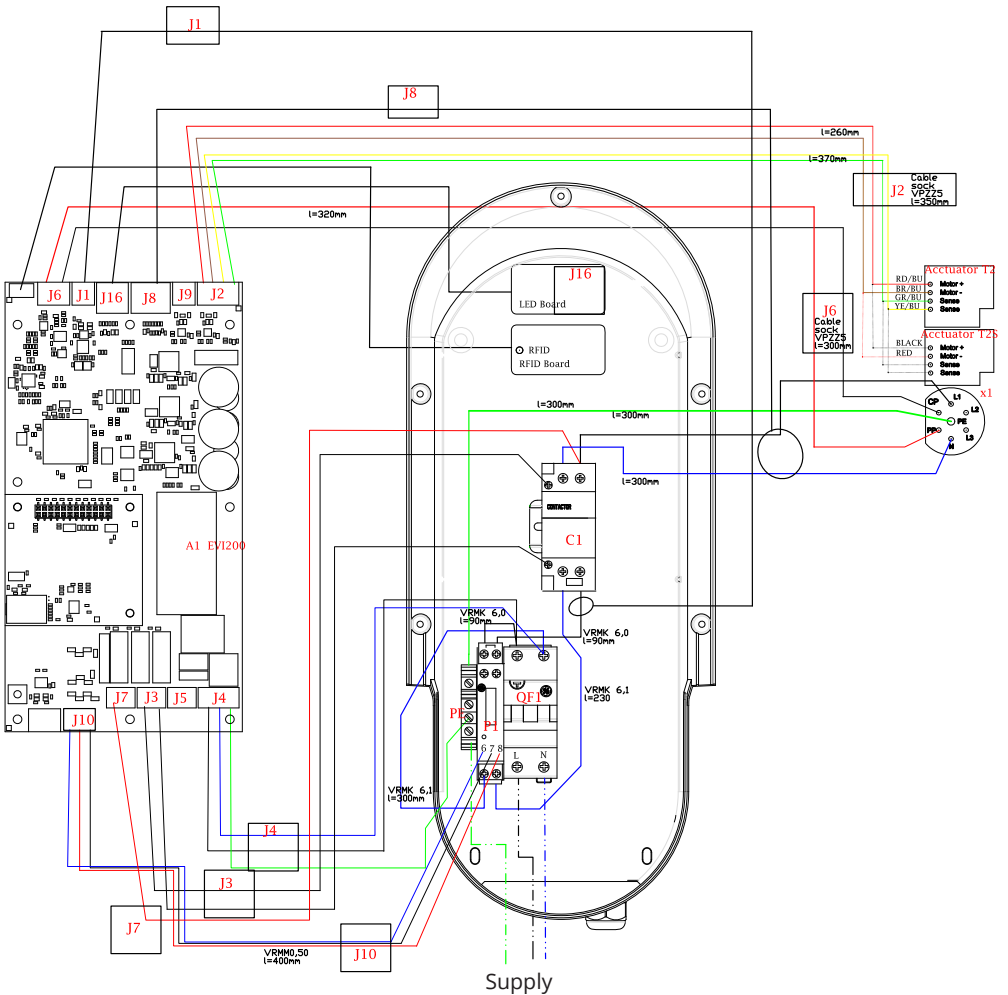

Note! All signal wires must be at a sufficient distance from the power wires or protected with insulating shield / plastic spiral.

# 14. EVH161-A2RMD internal circuit example

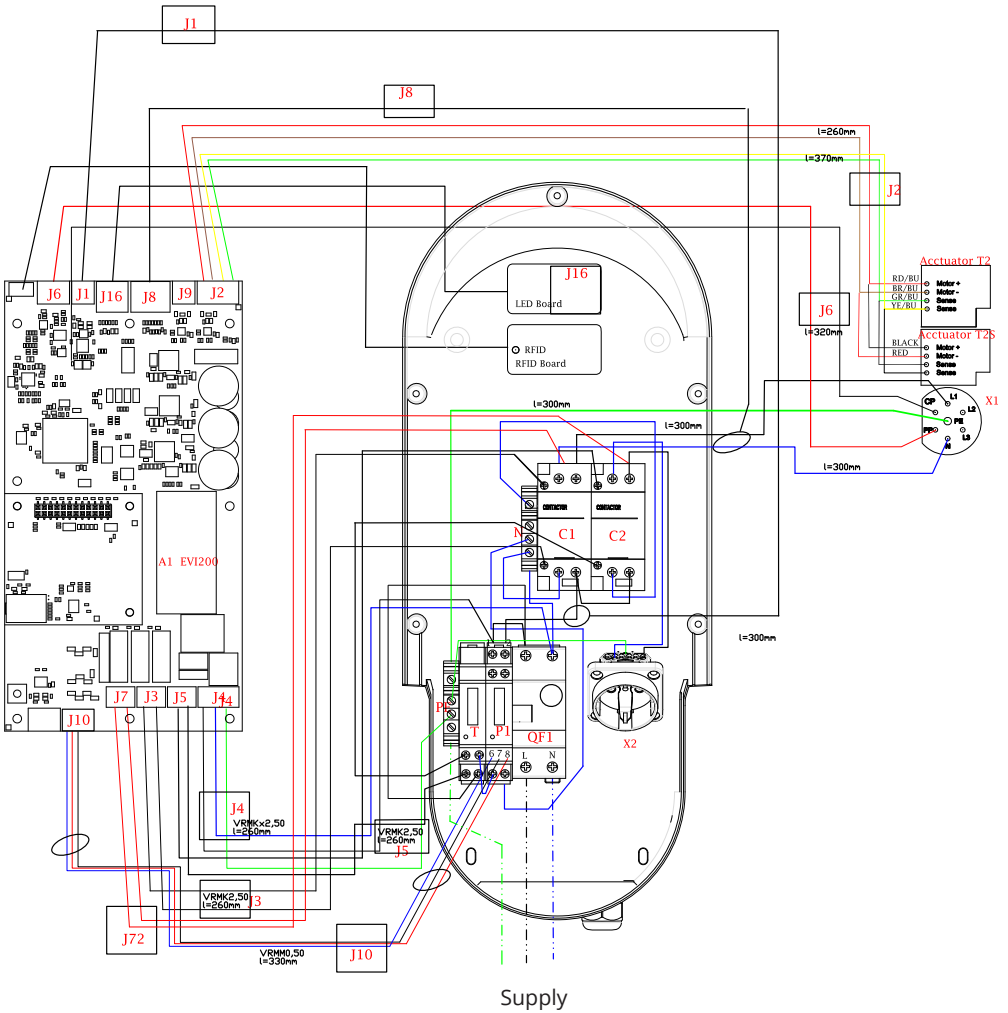

Note! All signal wires must be at a sufficient distance from the power wires or protected with insulating shield / plastic spiral.

# 15. EVH163-A2RM0 / EVH323-A2RM0 / EVH163-ASRM0 / EVH323-ASRM0 internal circuit example

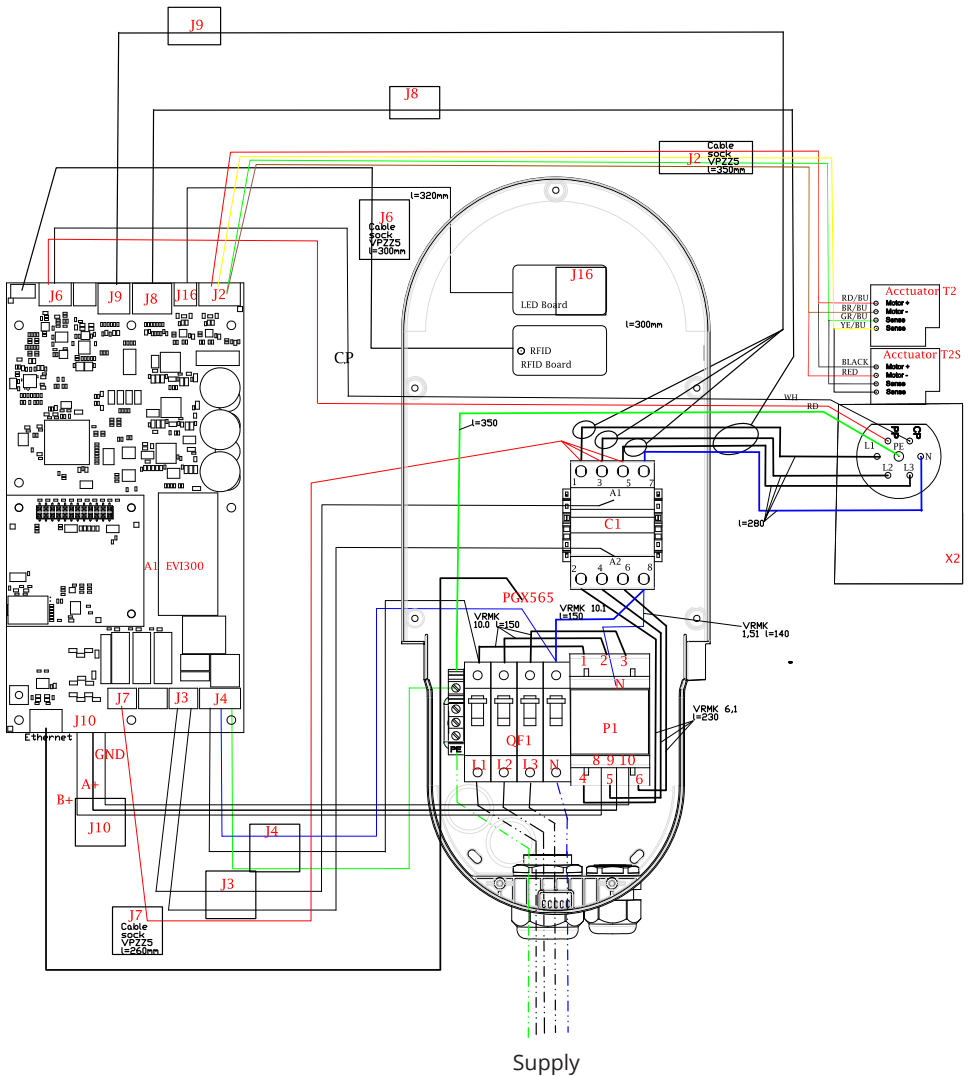

Note! All signal wires must be at a sufficient distance from the power wires or protected with insulating shield / plastic spiral.

## 16. Dimension drawing

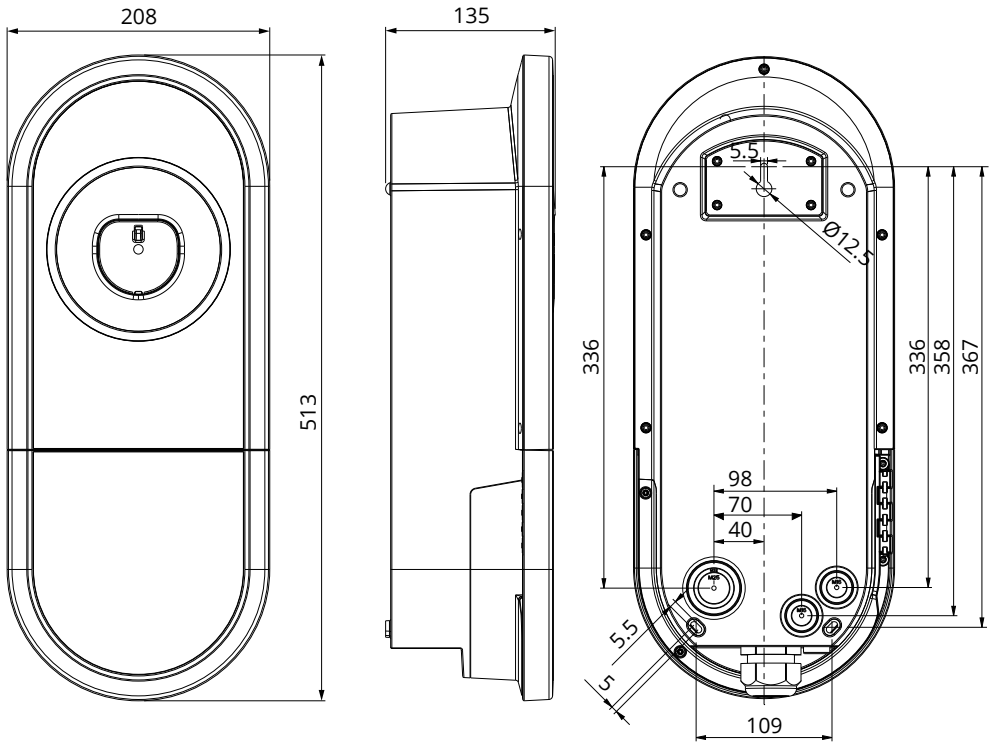

## 17. Troubleshooting

*Charging station is off, no lights on*

| Issue   | Corrective action           |
|---|-----------------------------|
| Mains voltage does not exist in the supply connectors (L1, L2, L3). | Ensure proper power supply. |
| The circuit breaker QF1 is off.                                     | Turn the QF1 on.            |

## 18. Disposal



*Do not dispose of electrical and electronic devices including their accessories with the household waste.*

- When the charger is at the end of its life cycle, it must be disposed of properly according to local recycling guidelines.
- The charger's cardboard packing is suitable for recycling.
- Dispose of the plastic wrap with the household waste or according to local recycling guidelines.

## 19. Warranty

Warranty conditions, see the product card on [www.ensto.com](http://www.ensto.com).

## 20. Declaration of Conformity

Hereby, Ensto Chago Oy declares that the Ensto One chargers are in compliance with the Directive 2014/53/EU. The full text of the EU declaration of conformity is available on request. Please see contact information on [www.ensto.com](http://www.ensto.com).



## 21. Ensto Charger Control Application

- With the Ensto Charger Control Application you can control the charger and change the settings of the charger.



*The use of this application is intended only for an electrically skilled person.*

- Bluetooth technology is used for the wireless connection.
- You can pair your mobile device to several chargers, but it can be connected only to one charger at a time.
- The range in free space is approximately 5m.

### 21.1. Installing the application

- Download the Ensto Charger Control application from Apple Store or Google Play.
- Open the application. In **“DEMO”** mode you can practice using the application.



Android version 5.0 and above  
iOS version 8.0 and above



Ensto Charger Control



## 21.2. Pairing the charger with your mobile device

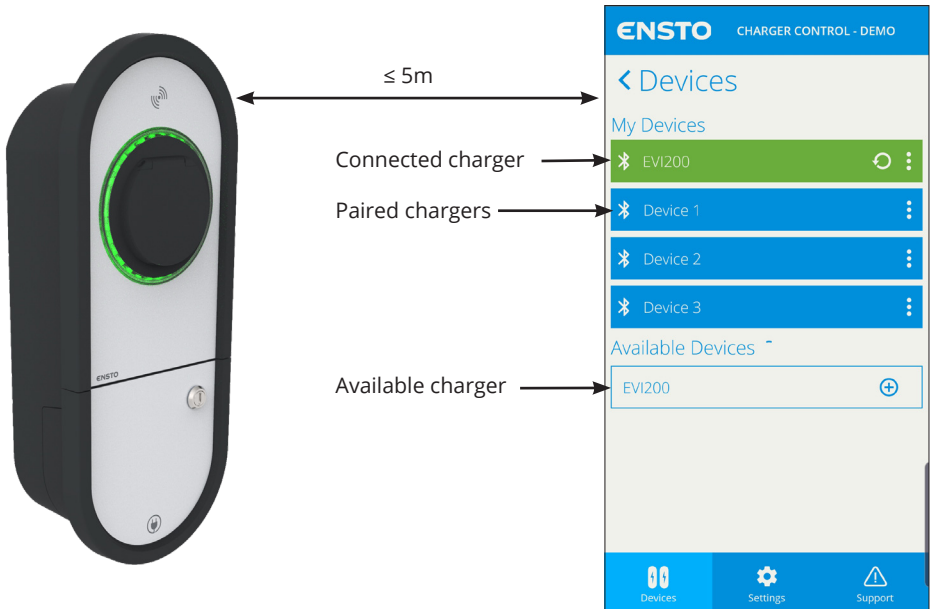

1. First switch off the charger from the main switch and then switch it on again.
2. Start the pairing procedure within 3 minutes.
3. Open the application.
4. Go to **"Devices"**.
5. Select from **"Available Devices"** the charger you want to pair with your mobile.
6. If the pairing fails the first time, try again starting from step 1.
7. When the pairing is completed, you can find your charger in **"My Devices"**.

If you want to control the charger with another mobile device, follow the pairing steps above.

**Note! The charger can be paired only to one mobile device at a time.**

## 21.3. Installer menu in the Ensto Charger Control Application



### WARNING

*Danger of electric shock! Risk of fire!*

- *Settings described in this chapter must only be done by an electrically skilled person.*

### Open the Installer menu

- Open the Ensto Charger Control on your mobile device.
- Go to **"Support"**.
- Press the letter **E** on the **ENSTO** logo for a long time.
- In the installer menu available features depend on the charger model.

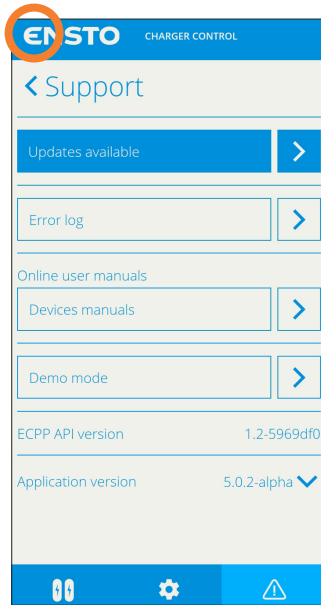

### 21.3.1. Self test

- The charger performs a self test automatically at start-up.
- During the self-test, several components and their proper function is tested.
- The LED indicator is stable green during the self test.
- The extent and duration of the self test depend on the charger model.
- If a critical fault is detected during the self test, the charger will go to error state. You can see the error code in the **"Error log"**.

### 21.3.2. Connection settings

These are the factory default connection settings to the backend system. **Change them only if it is absolutely necessary.**

When the Dynamic Host Configuration Protocol (DHCP) is not used, please consult your local IT network administrator in case you have any questions.

#### NTP (Network Time Protocol)

Default: [0.europe.pool.ntp.org](http://0.europe.pool.ntp.org)

Address to a NTP server, which is used to synchronize the clock.

#### MQTT (Message Queuing Telemetry Transport)

Default: [a24dm43br7rybm-ats.iot.eu-west-1.amazonaws.com](https://a24dm43br7rybm-ats.iot.eu-west-1.amazonaws.com)

Ensto uses Amazon services. The IP address can change at any time.

<https://docs.aws.amazon.com/general/latest/gr/aws-ip-ranges.html>

#### Use DHCP

Default: Enabled

#### IP address

If the DHCP is not used you can specify the static IP address here.

#### Default gateway address

Default gateway if the DHCP is not used.

#### Subnet mask

The device uses a default subnet mask If the DHCP is not used. The device uses addresses

### 21.3.3. Update device firmware

This menu is visible if a firmware update is available.

We recommend that you update the firmware to ensure that the charger works properly.

### 21.3.4. Maximum charging current



*The setting of the maximum charging current must comply with the system dimensioning.*

If the electric system dimensioning on the installation site requires a lower charging current than the charger's nominal value, you can change the setting in this menu.

### 21.3.5. Connected phases

Select the phase the charger is connected to. The Dynamic Load Management (DLM) server needs this information.

### 21.3.6. Phase rotation (only 3-phase chargers)

You can balance the load between the phases L1, L2 and L3 using phase rotation.

For example in a charging system which includes several chargers:

Charger 1 => RST (L1 / L2 / L3)

Charger 2 => TRS (L3 / L1 / L2)

Charger 3 => STR (L2 / L3 / L1)

The Dynamic Load Management (DLM) server needs this information.

### 21.3.7. Dynamic Load Management (DLM)

Enable / disable the DLM server. The DLM server is managed by Ensto.

Note! You need to registrate in <https://www.research.net/r/25YZMS8?lang=en>

### 21.3.8. Offline current

The maximum charging current in case the connection to the Dynamic Load Management (DLM) server is interrupted.

### 21.3.9. Eathing System

The default setting for power supply is TN network. If you connect the charger to an IT network, you have to change settings for the charger accordingly.

### 21.3.10. Overcurrent limit

- Certain car models tend to take more charging current than set as the charger's maximum charging current.
- In case an overcurrent of 10% lasts longer than 3 minutes, it results an error state. If the overcurrent is 16% it results an error state immediately.
- You can prevent unnecessary error states by setting an overcurrent limit.
- If the charging current is lower than 10A, you can set the overcurrent limit up to 30%.

## 21.4. Error messages

At error state, an error code appears on the screen of your mobile device. See the table below for the cause and corrective actions.

| Error code | Issue   | Corrective action  |
|------------|---|--|
| E01        | The charger has received incorrect information from the vehicle.                        | Switch off the charger from the main switch and then switch it on again. If the error occurs again, contact service.   |
| E02        | The fault current detection sensor is defective.  | Contact service.   |
| E03        | The charger has an internal malfunction.  | Contact service.   |
| E04        | The charger has an internal malfunction.  | Contact service.   |
| E05        | The charger has detected fault current in the charging circuit.                         | Switch off the charger from the main switch and then switch it on again. If the error occurs again, contact service.   |
| E06        | A fault in the charge contactor has tripped the system's protection device RCBO.        | Turn on the protection device RCBO. If the error occurs again, contact service.  |
| E07        | The charger was unable to identify the current-carrying capacity of the charging cable. | The charging cable may be defective. Restart the charger. If the error occurs again, try charging with another charging cable.   |
| E08        | The charger has detected a malfunction in the vehicle.                                  | Switch off the charger from the main switch and then switch it on again. If the error occurs again, take your vehicle to service. If possible, try charging another vehicle. |
| E09        | The charger is overheated.  | Let the charger cool down and try again. If the charger is in an exceptionally warm environment, try lowering the ambient temperature.                                       |
| E10        | The vehicle has exceeded the permitted charging current.                                | Switch off the charger from the main switch and then switch it on again. If the error occurs again, take your vehicle to service. If possible, try charging another vehicle. |
| E11        | The charger has a malfunction.  | Contact service.   |
| E12        | The charger has detected a software error.  | Contact service.   |

|     |  |  |
|-----|--|--|
| E13 | The charger has detected a short circuit in the charging cable.  | The charging cable may be defective. Switch off the charger from the main switch and then switch it on again. If the error occurs again, try charging with another charging cable. |
| E14 | A failure occurred while locking the charging cable to the charger or unlocking the charging cable from the charger. | Make sure there is no tension on the charging cable. Push the plug deeper into the socket and try again. If the error occurs again, contact service.                               |
| E15 | The charger has an internal malfunction.   | Switch off the charger from the main switch and then switch it on again. If the error occurs again, contact service.   |
| E16 | The charger has an internal malfunction.   | Switch off the charger from the main switch and then switch it on again. If the error occurs again, contact service.   |
| E17 | The charger cannot connect to the backend system.  | This error may not be due to the charger itself. The problem may be with your network service provider.  |
| E18 | A fault in the charge contactor has tripped the system's protection device RCBO.                                     | Turn on the protection device RCBO. If the error occurs again, contact service.  |
| E19 | The vehicle has performed an operation that is not supported by the charger.   | The charger and the vehicle are incompatible with certain features. The charger can partially charge the vehicle. The incompatibility will not damage the charger or the vehicle.  |
| E20 | The energy meter does not communicate with the charger.  | Contact service.   |
| E21 | The control circuit on the charge contactor has a malfunction.   | Switch off the charger from the main switch and then switch it on again. If the error occurs again, contact service.   |
| E22 | Software certificate on the charger is missing or corrupted.   | Contact service.   |
| E23 | Charger's RFID reader is defective.  | Switch off the charger from the main switch and then switch it on again. If the error occurs again, contact service.   |

If you need to contact Ensto related to faulty operation of the charger, go first to "**Support / Error log**". Save the error log information before contacting. This information helps the technical support and maintenance to resolve the issue.

**Note!** In some situations the charger automatically returns to normal operation within approximately 5 minutes after disconnecting the charging cable.



**ENSTO**

Ensto Chago Oy  
Ensio Miettisen katu 2, P.O. Box 77  
FIN-06101 Porvoo, Finland  
Tel. +358 204 76 21

