

Ensto Wallbox



Installation Instructions
User Guide

Contents

Installation Instructions

1. Safety instructions.....	3
2. Description of symbols.....	3
3. Abbreviations.....	4
4. Delivery contents.....	4
5. Accessories.....	5
6. Mounting instructions.....	8
6.1. Before installation.....	8
6.2. Wall mounting with wall bracket.....	9
6.3. Ground mounting on concrete casting with ground mounting pole.....	10
6.4. Ground mounting on concrete foundation with ground mounting pole.....	11
6.5. Ground mounting on Unimi concrete foundation.....	12
6.6. Attaching charging station to mounting pole EVTL43.00.....	14
7. Electrical connections.....	15
7.1. Wiring instructions.....	15
7.2. Power supply.....	16
8. Commissioning.....	18
8.1. View of the component layout on the control unit.....	18
8.2. Connecting to the charging station.....	19
8.3. Ethernet connections.....	20
8.4. WiFi coverage area.....	20
9. Technical data.....	21
10. Code key.....	23
11. Dimensional drawing.....	24
12. Installation / Commissioning checklist.....	26
13. Maintenance / Preventive maintenance instructions.....	27
14. Testing instructions for the electric protective device.....	28
15. Troubleshooting.....	28
16. Warranty.....	29
17. Declaration of Conformity.....	29
18. Disposal.....	29

User Guide

19. User interfaces.....	30
20. Charging.....	30
20.1. Free charging.....	30
20.2. Charging with RFID.....	31

Installation Instructions

1. Safety instructions



Electrically skilled person

- The installation must only be done by a qualified professional.
- Read these instructions carefully before you install, operate or maintenance the charging station.
- Obey the instructions in this manual and make sure that the installation complies with national safety regulations, installation methods and restrictions.
- The information provided in this manual in no way exempts the installer or user from responsibility to obey all applicable safety regulations.
- Keep this manual for future installation and maintenance.



WARNING

Danger of electric shock! Risk of fire!

- *Improper installation can cause personal injury and property damage.*
- *Do not switch on the power supply before the installation work is completed.*

2. Description of symbols

	WARNING - Indicates a hazard with a medium level of risk which, if not avoided, could result in death or serious injury or considerable damage to the equipment.
	Electrically skilled person
	Identifier for plug and socket outlet AC / EN62196-2 / Type 2
	Radio-frequency identification reading area for automatical identifying of RFID tags.
	Environmental instructions



3. Abbreviations

Abbreviation	Description
LED	Light Emitting Diode
MCB	Miniature Circuit Breaker, protects cables from over load and short circuits
OCP	Open Charge Point Protocol, protocol how the charger communicates with the backend systems
RCBO	Residual current Circuit Breaker with Overcurrent protection
RCD	Residual Current Device, protects humans and animals from electric shock
RDC-DD	Residual direct current detecting device
RFID	Radio Frequency Identification, information remote reading/writing system, here used to identify authorized charging point users
USB	Universal Serial Bus, specifications for cables, connectors and protocols
RS-485	Recommended Standard 485, standard defining the characteristics of drivers and receivers for use in serial communications systems

4. Delivery contents

- Charging station
- Label set with RCBO testing instructions (EVB100B-B4BC)
- Triangular key
- Installation Instructions / User Guide in English, other languages please see <https://evwiki.ensto.technology/>

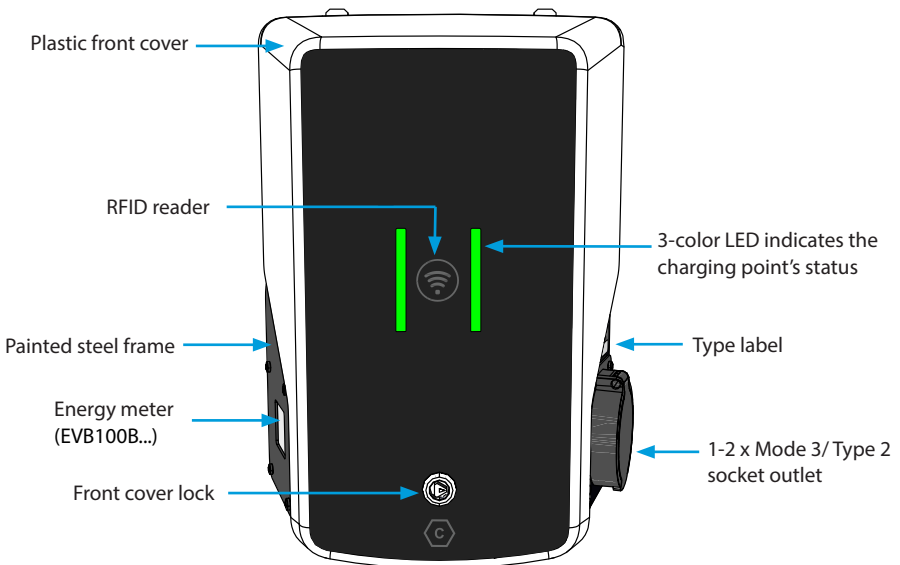

5. Accessories

Flange KOT21715

Included in the delivery.

Note! Cable glands are not included in the delivery.

Please order suitable cable glands separately according to the used supply cable sizes, for example Ensto KTM... cable gland series (polyamide or brass).

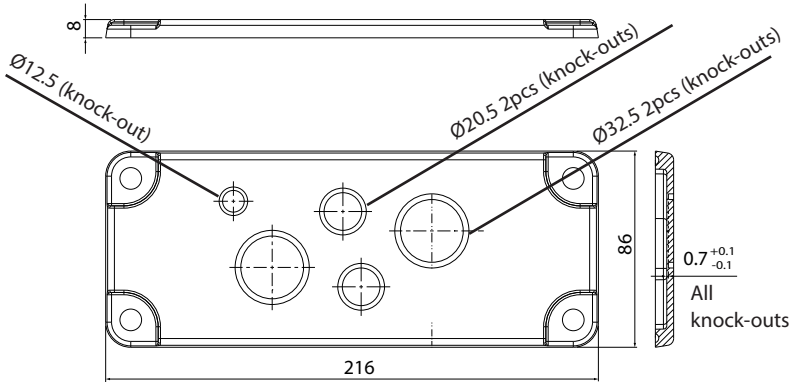

EVTL40.00

Wall bracket

The wall bracket is pre-installed to the charging station.

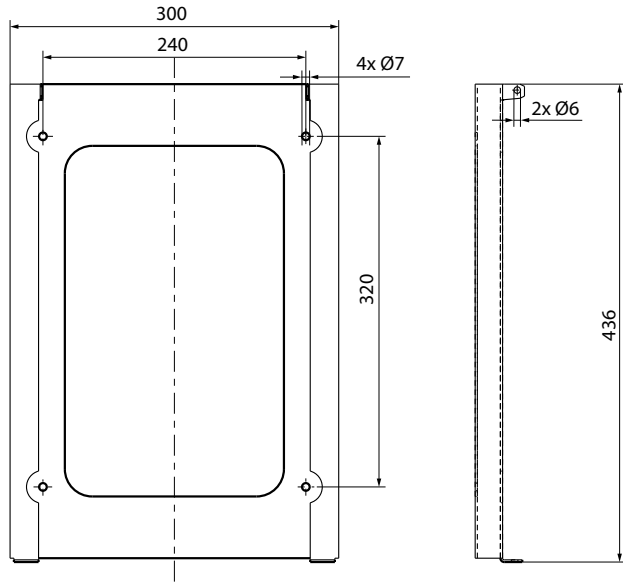

EVTL43.00

Ground / Floor mounting pole

The delivery includes flange F2202.

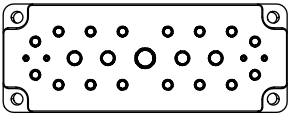

Flange 2202

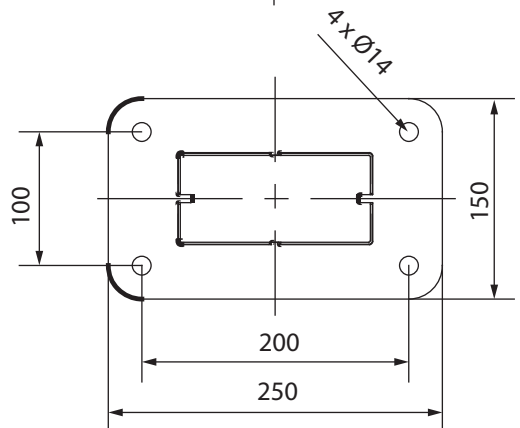
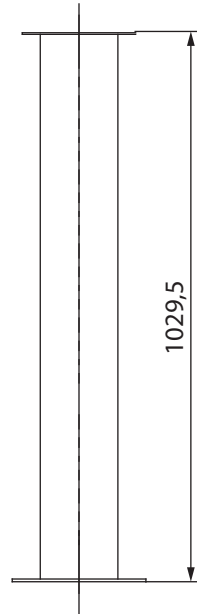
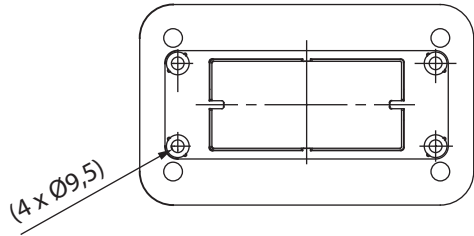

EVTL44.00

Adapter for ground mounting

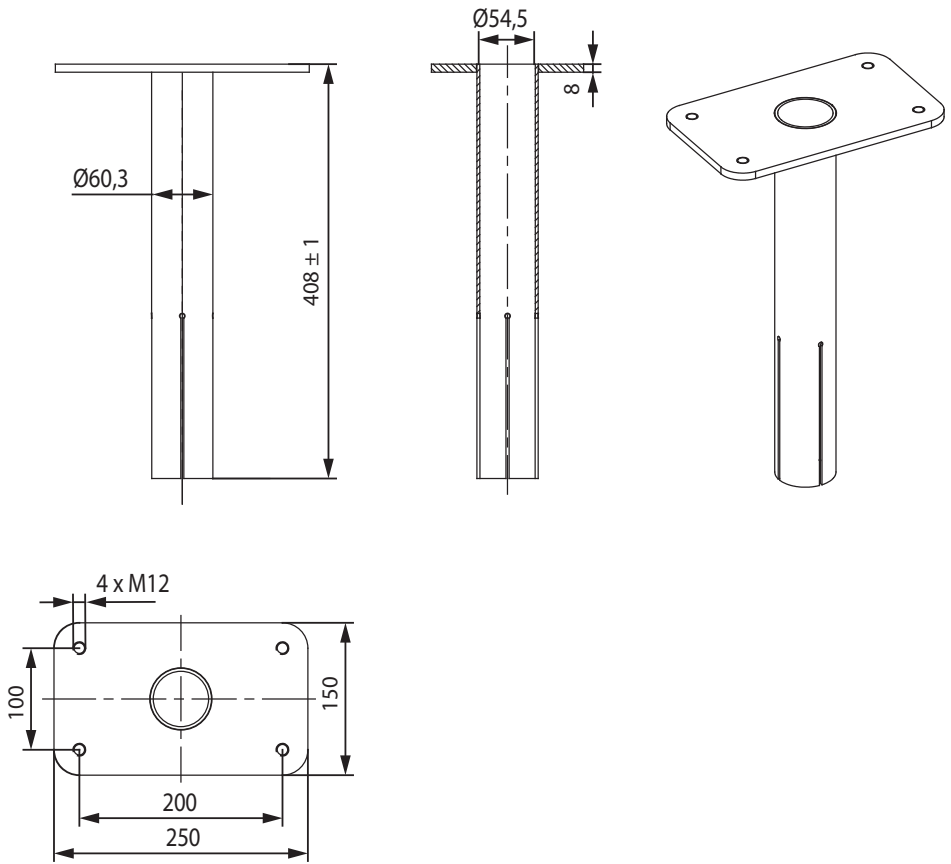

6. Mounting instructions

6.1. Before installation

Remove the the charging station from its package. Do not scratch the surface of the the charging station after removal from the package.

When selecting installation site, take into consideration the following:

- The minimum space necessary for operating and maintenance.
- Make sure that the mounting foundation is applicable and robust.
- To ensure the optimal charging performance, the the charging station should not be exposed to direct sunlight.
- If the charging station is installed in corrosive conditions where there is a risk of metal rusting, visible metal surfaces must be protected regularly with anti-corrosion agent.

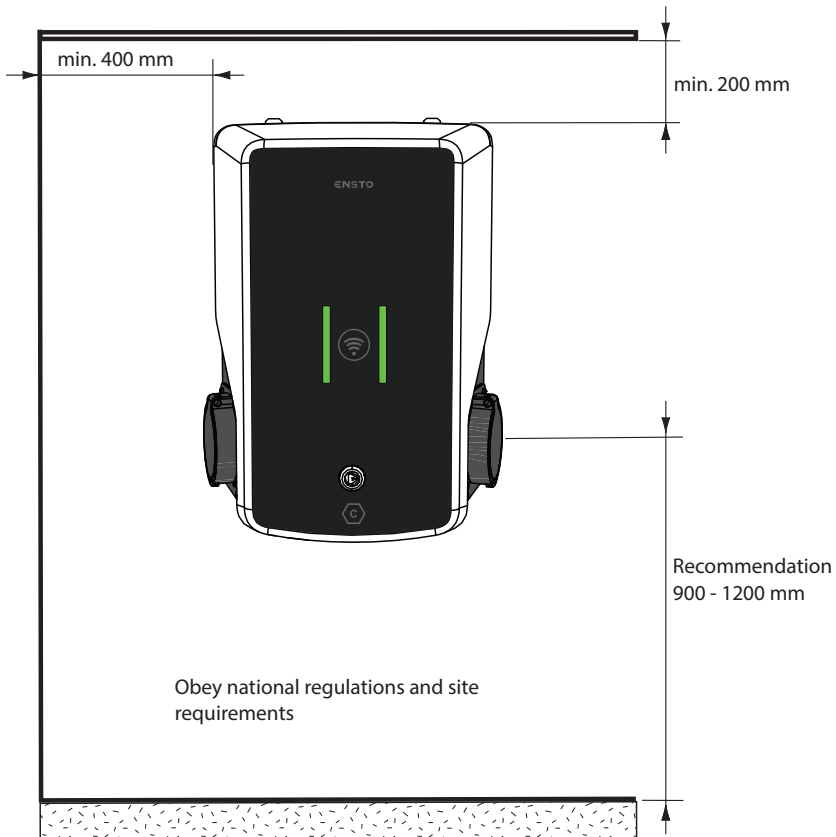

6.2. Wall mounting with wall bracket

Installation accessories	Wall bracket EVTL40.00	1 pcs
	Screws	4 pcs

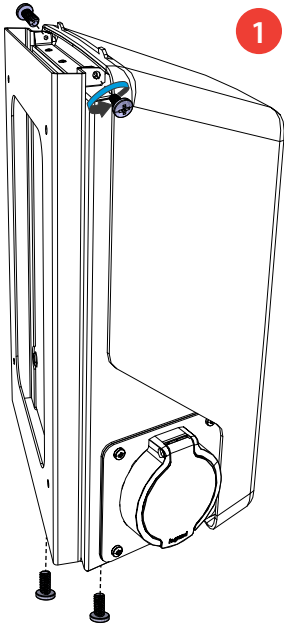

Installation steps

1. Remove the pre-installed wall bracket from the charging station [1]. Loosen the 2 fastening screws from the top of the charging station and 2 fastening screws from the bottom.
2. Drill screw holes for the wall bracket [2].
3. Attach the wall bracket to the wall. Select applicable screws for the wall.
4. Attach the charging station to the wall bracket with the 4 fastening screws you removed in the step 1.
5. See wiring instructions on page 15.

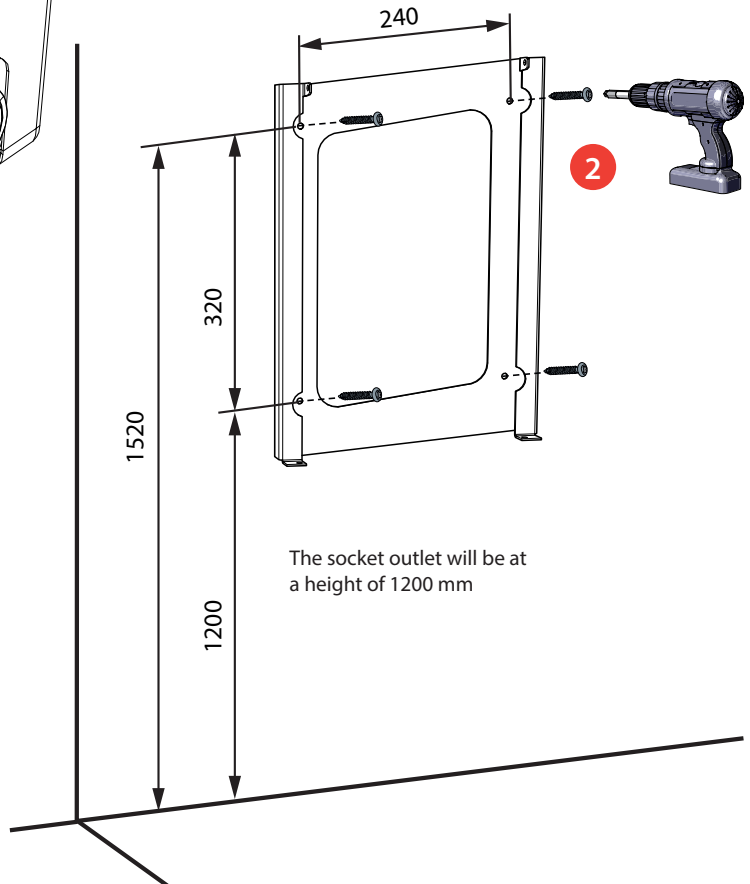

6.3. Ground mounting on concrete casting with ground mounting pole

Installation accessories	Ground mounting pole EVTL43.00	1 pcs
	Anchor bolts M12	4 pcs
	Bolts and nuts (not included)	

Make sure that the materials used for the concrete casting and the installation procedures follow local building regulations and safety standards.

- Dig a trench for cable conduits and an excavation pit for the concrete foundation. The pit floor should be compacted and level.
- Put cable and possible drain pipes in place.
- Fill the pit with concrete.
- Let the concrete cure. Make sure that the surface stays level during the process.

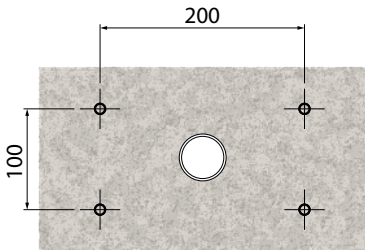
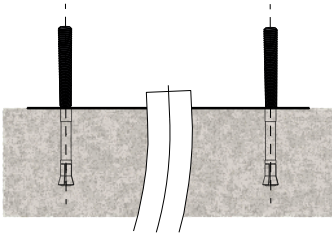

Installation steps

1. **Make sure that the concrete surface is compacted and level.**
2. Drill a hole in the concrete for the anchor bolts. For more information, please see the anchor bolt instructions.
3. Put the anchor bolts in place.

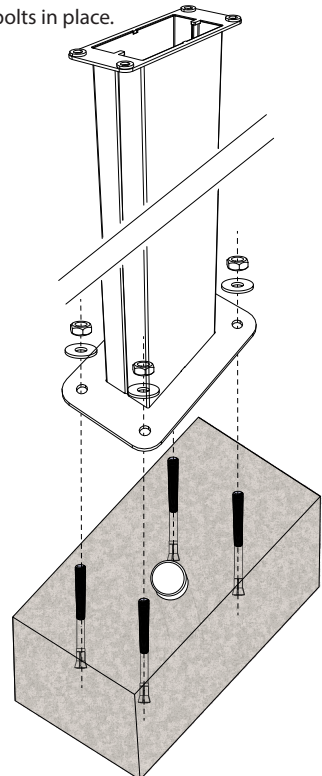

4. Pull the electric cables approx. 1500 mm measured from the concrete surface.
5. Attach the ground mounting pole to the anchor bolts with washers and nuts.
6. Pull the electrical cables through the ground mounting pole.
7. Attach the charging station to the mounting pole. See instructions on page 14.

6.4. Ground mounting on concrete foundation with ground mounting pole

Installation accessories	Ground mounting pole EVTL43.00	1 pcs
	Adapter for concrete foundation EVTL44.00	1 pcs
	Concrete foundation (from different manufacturers)	1 pcs
	Bolts, washers and nuts (not included)	

Installation steps

1. Dig a trench for cable conduits and an excavation pit for the concrete foundation to applicable depths.
2. Add gravel to the bottom of the pit, to such thickness that the top of the foundation will be at applicable level when you lift the foundation into the pit. Take into consideration the possible paving materials when you set the level.
3. Lift the concrete foundation into the installation pit. For more information, please see the concrete foundation mounting instructions.
4. Put cable and possible drain conduits in place.
5. Lift the adapter EVTL44.00 into the concrete foundation. Cut the adapter, if necessary. Adjust the adapter in such a manner, that the top surface of the adapter is horizontal. Make sure, that the adapter is securely in place and does not swing.
6. Pull electric cables through the conduits and the adapter approx. 1500 mm measured from the adapter flange.
7. Tighten the foundation to its place by filling the excess space outside the foundation with gravel.
8. Attach the ground mounting pole to the adapter with bolts, washers and nuts (included).
9. Pull the electrical cables through the ground mounting pole.
10. Attach the charging station to the mounting pole. See instructions on page 14.

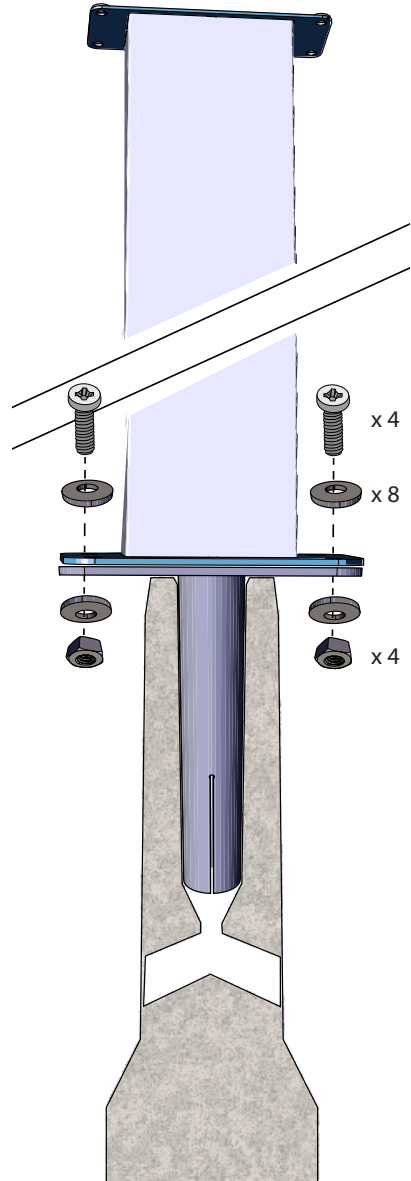

6.5. Ground mounting on Unimi concrete foundation

This installation example describes the installation procedure when a concrete foundation supplied by Unimi - Solutions is used.

Installation accessories	Ground mounting pole EVTL43.00	1 pcs (1 x EVB)
		2 pcs (2 x EVB)

Installation accessories, order from www.unimi.se	Concrete foundation	1 pcs
	Cover plate	1 pcs
	Adapter for 1 x EVB, product code US7650	1 pcs
	Adapter for 2 x EVB, product code US27657	1 pcs

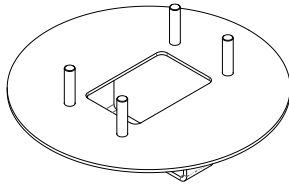

US7650

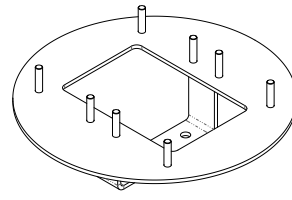

US27657

Note! When using the adapter for two charging stations (US27657), you can get up to four charging outlets.

Installation steps

1. Dig a trench for cable conduits and an excavation pit for the concrete foundation to applicable depths. The pit floor should be compacted and level.
2. Adjust the depth of the pit so that the top of the foundation will be flush with the final surrounding ground surface. Take into consideration the possible paving materials.
3. Cover the unused conduit openings with plugs, which are included in the foundation delivery.

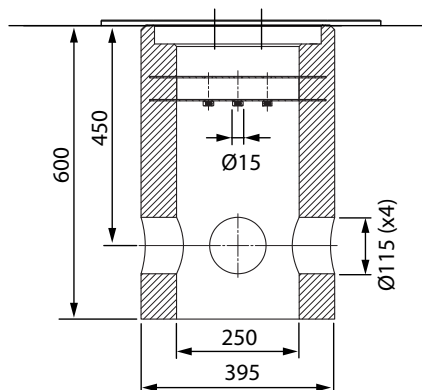

4. Lift the foundation into the installation pit. You can use the attachment bar in the foundation as a lifting point. Make sure that the mounting bar is in a direction that enables the installation of the charging station in correct position.
5. Put cable conduits into the trenches and install the conduits to relevant inlets.
6. Pull electric cables through the conduits into the foundation approx. 1500mm measured from the top of the foundation.
7. Tighten the foundation to its place by filling the excess space outside the foundation with gravel.
8. Set the final layer of gravel so that the top of the foundation will be flush with ground or the final paving material.
9. Always put a cover plate on the foundation, if the charging station is installed in a separate session than the foundation.
10. Remove the cover plate before you start the installation work.
11. Put the adapter element on the foundation.
12. Attach the adapter element to the foundation attachment bar with bolts 3 pcs (included).
13. Put the mounting pole on the adapter. Tighten with the washers and nuts included in the delivery.
14. Pull the electrical cables through the mounting pole.
15. Attach the charging station to the mounting pole. See instructions on page 14.

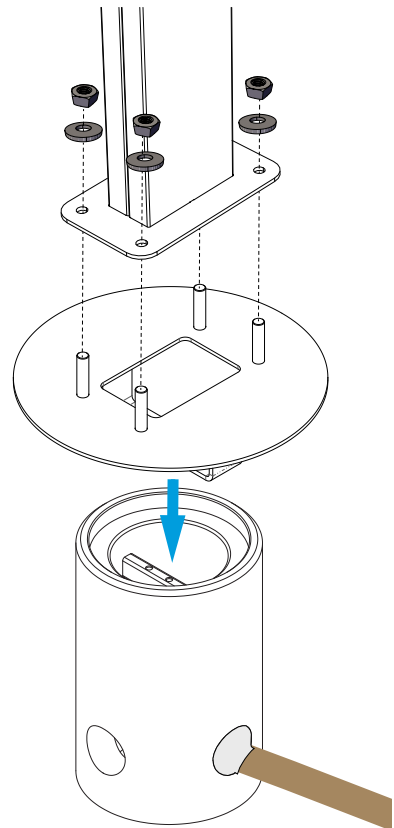

6.6. Attaching charging station to mounting pole EVTL43.00

Installation steps

1. Open the front cover lock and remove the front cover.
2. Remove the flange at the bottom of the charging station frame. Use the multigate gland plate F2202 (included in the mounting pole delivery) to make sure that the ingress protection rating will be sufficient.
3. Pull the electrical cables through the applicable glands of the F2202.
4. Attach the charging station and the gland plate F2202 to the mounting pole with the screws you removed in the step 2.

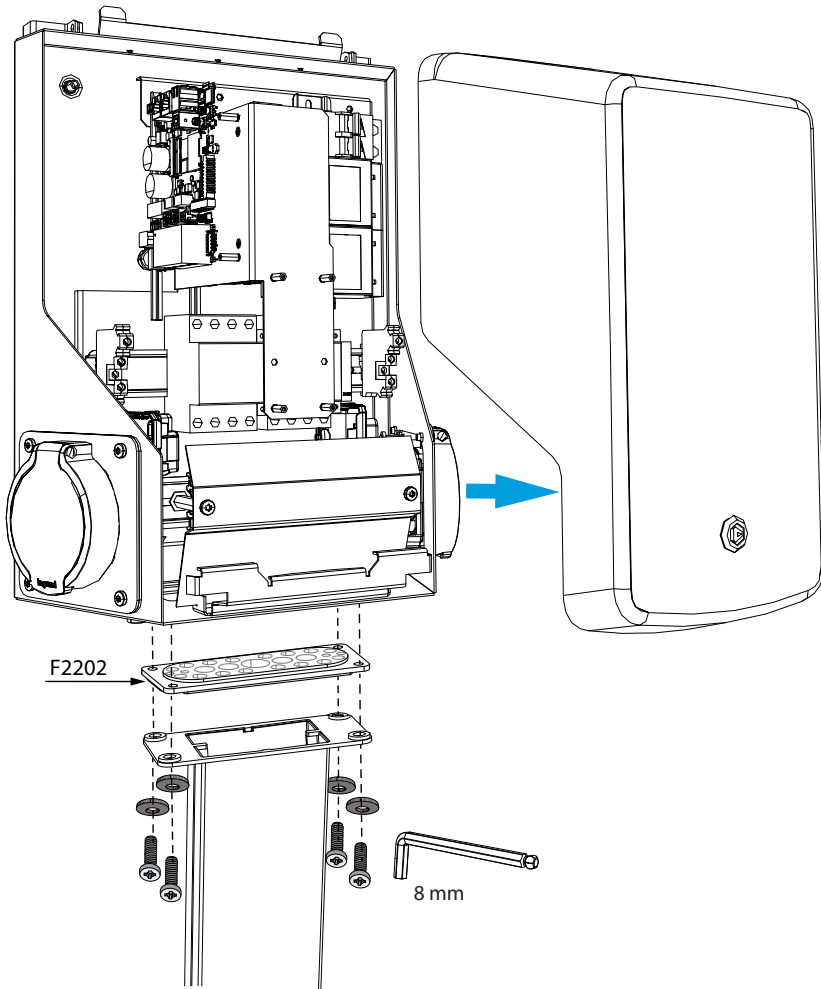

7. Electrical connections

7.1. Wiring instructions

1. Open the front cover lock and remove the front cover.
2. Remove the plastic shield.
3. You can remove the steel bracket on the front, if it is necessary to get more space during the installation work.
4. Remove the cable sheath approx. 150 mm.
5. Pull the supply cable through the cable gland approx. 200mm measured from the cable gland.
6. Cut the supply cable conductors to applicable lengths. The earth conductor must be long enough, so that if a fault occurs it is the last one that comes loose.
7. Strip the conductors 10 - 12 mm and connect to the supply connectors.
8. Attach the steel bracket in place.
9. Attach the plastic shield to correct position.
10. Close the front cover.

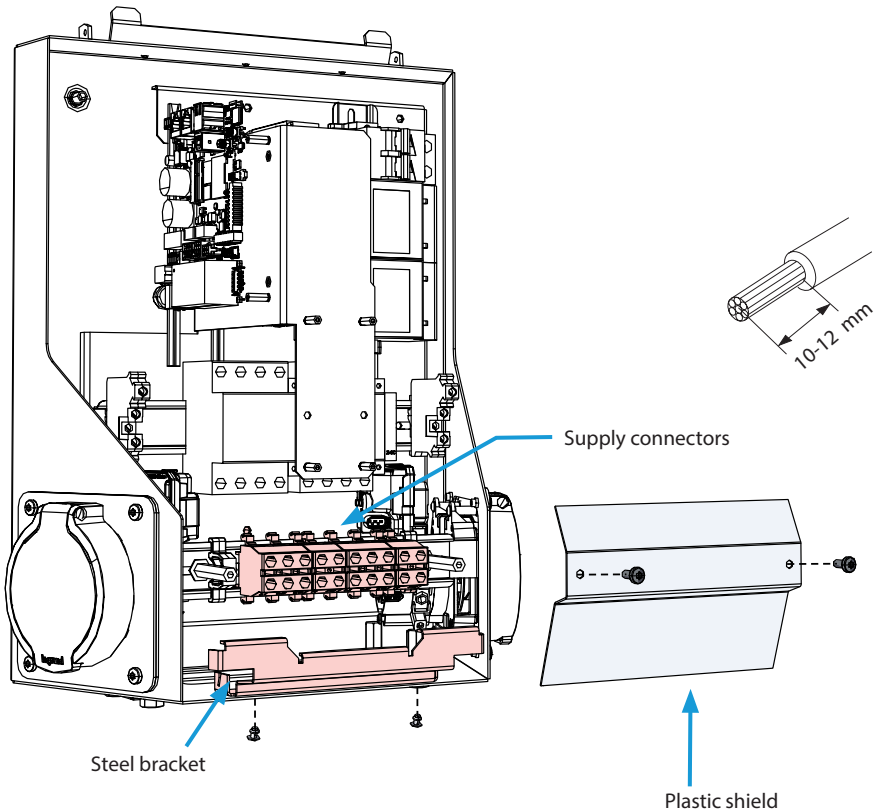

7.2. Power supply

The voltage and current ratings including cables and line protector dimensioning must comply with national regulations. System dimensioning must be done by a qualified electrical designer.

Connect separate supply cables for each charging outlet.
We recommend supply cables with stranded conductors.

Supply connection to charging station with one outlet

EVB100B-B4BC

- A combined device with residual current circuit breaker and over current protection (RCBO) is integrated in the charging station.
- A label set of RCBO testing instructions is included in the delivery. Attach a language specific label on the charging station on a position where it can be seen.

EVB100B-A4BC

- A Residual current protection device (RCD type A, 30mA) and a circuit breaker (MCB max. 32A) for each charging outlet must be installed in the switchboard.

TN network

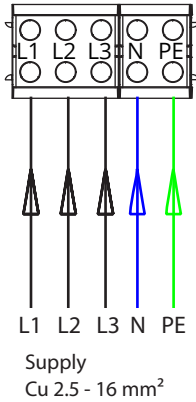

IT network

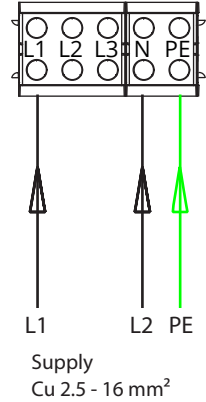

If you connect the charging station to an IT network, you must set the energy meter to 2-phase mode from the energy meter settings.

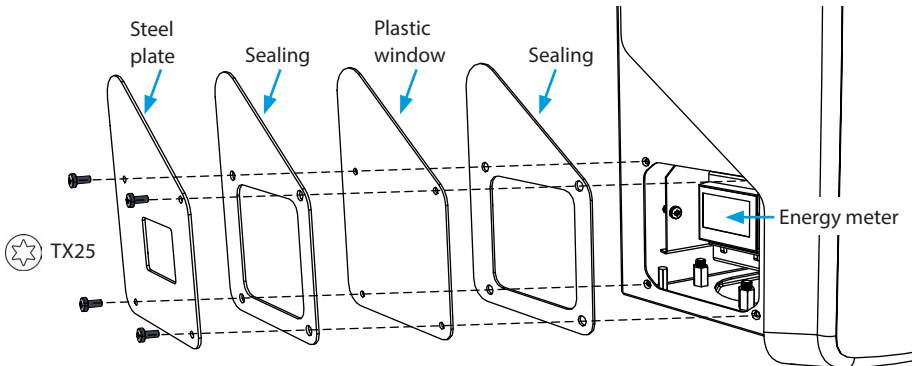

Supply connection to charging station with two outlets

EVB200B-A4BC

- A Residual current protection device (RCD type A, 30mA) and a circuit breaker (MCB max. 32A) for each charging outlet must be installed in the switchboard.

Note! Phase rotation inside the charging station is not allowed.

TN network

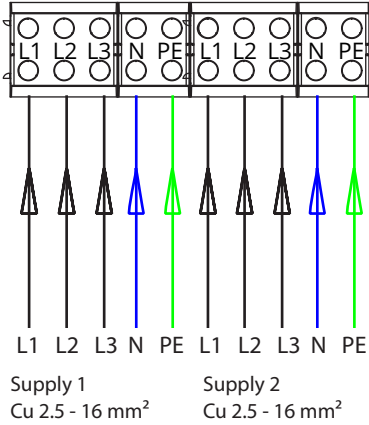

IT network

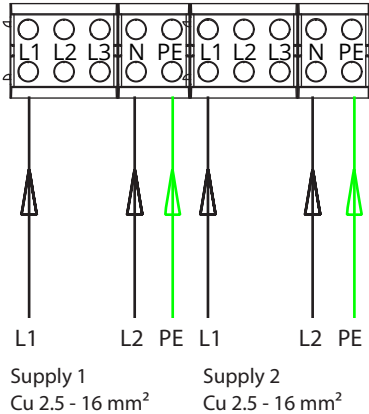

If you connect the charging station to an IT network, you must set the energy meters to 2-phase mode from the energy meter settings.

Remove the front cover of the charging station.
The energy meters are installed on the right side.



8. Commissioning

Before commissioning the charging station must be installed according to the installation instructions.

By default all charging stations are operating in free charging mode (standalone operation). In this free charging mode external communication (Ethernet, 4G, LAN or WiFi) is not active. If you connect the charging station to some back-office (online mode), first make sure that the basic functionality is working before establishing communication.

8.1. View of the component layout on the control unit

Component	Connection	Note
USB B Service port	Computer to the charging station	EVB200: Connect to the right side
Ethernet 1 / 2	Ethernet communication cable	EVB200: Connect input to the left side
Micro SIM card holder	Connection to mobile network	EVB200: The holder is on the left side
Optocoupler input (+ / - 12V)	Control of charging event via external device / input	External input operation must be configured on charging station settings. Please ask your Ensto representative for details.

EVB100...

EVB200... control unit on the left side

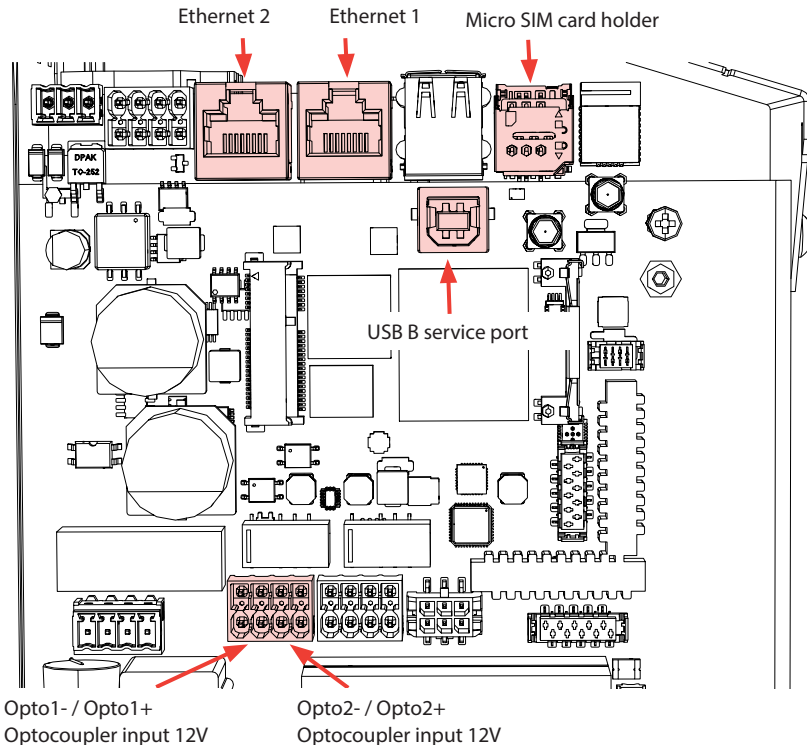

EVB200... control unit on the right side

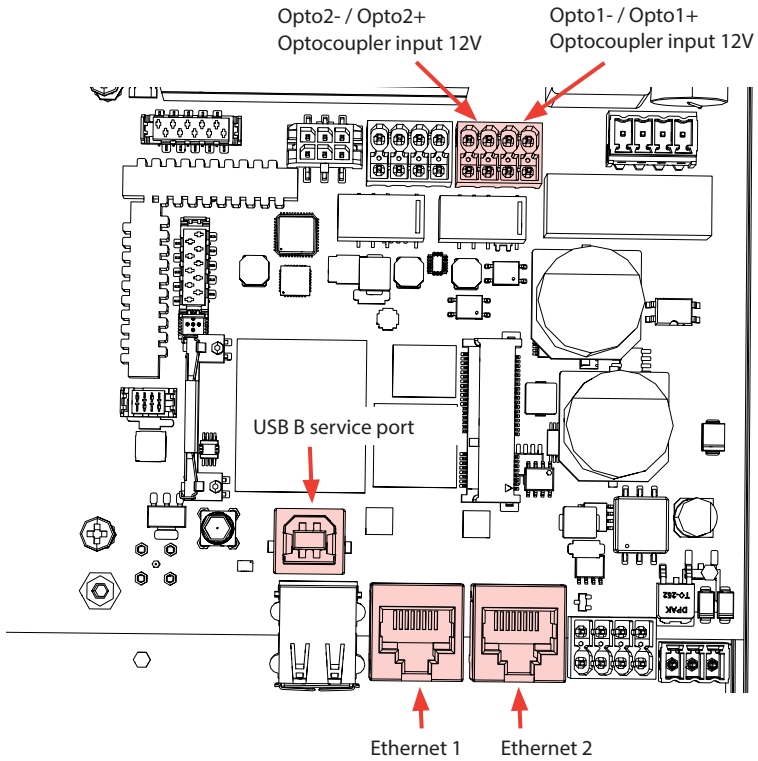

8.2. Connecting to the charging station

If you want to change the default settings, you must connect to the charging station via web configuration tool to be able to start configure the commissioning settings. Use Firefox, Chrome or Windows Edge web-browser for configuring.

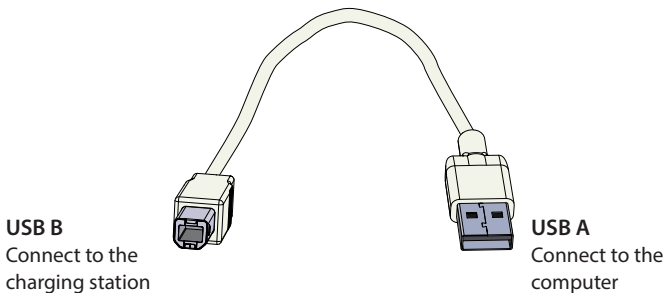

8.3. Ethernet connections

Chaining the Ethernet connections is allowed.

EVB200: Connect the Ethernet input to the ETH1 connector on the left side control unit.

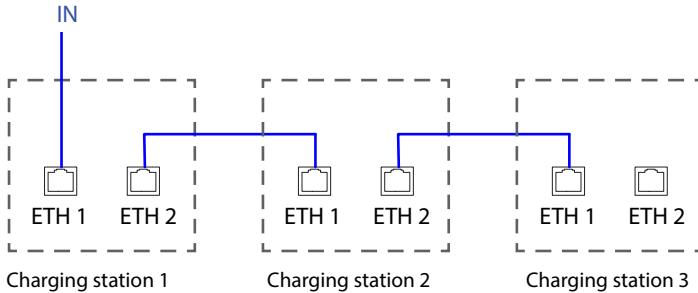

8.4. WiFi coverage area

Examine the available signal strength to make sure that the communication (4G, WiFi), reception and connectivity are working.

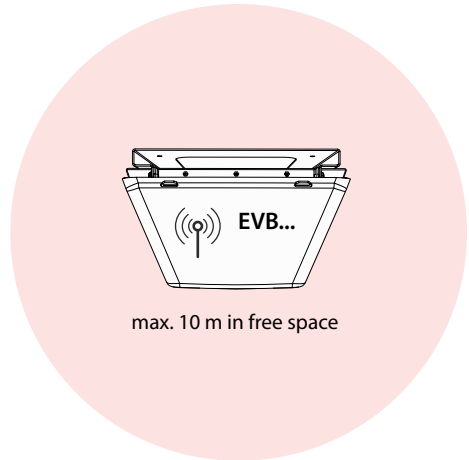

If you want to use a WiFi network, first do a WiFi survey to make sure that the network works correctly. The survey helps you to identify potential issues and optimize coverage.

General steps how to do a WiFi survey

1. Plan the survey.
Define the purpose of the survey: estimate coverage, identify dead spots, optimize performance etc. Define the survey areas, including indoor and outdoor spaces.
2. Collect necessary tools.
Get a WiFi survey tool or software. There are various free and commercial options available, such as Ekahau, NetSpot and Acrylic Wi-Fi Home.
3. Prepare the survey environment.
Make sure that the WiFi network is working. Make sure that in the survey area are not any objects or interference sources that may affect signal propagation, such as large metal objects or other electronic devices.

4. **Configure survey settings.**
Set the parameters in the survey tool based on your requirements. Select the appropriate frequency bands (2.4 GHz), set the channel width and specify the survey duration.
5. **Do the survey.**
Walk through the survey area by following a systematic path, while the survey tool records the WiFi signal strength and other relevant data. Take note of the specific locations where measurements are taken.
6. **Analyze the survey data.**
After the survey is completed, use features of the survey tool to analyze the collected data. Look for areas with low signal strength, high interference, or excessive co-channel and adjacent-channel interference. Identify potential sources of interference or coverage gaps.
7. **Take corrective measures.**
Based on the survey results, take necessary actions to optimize the WiFi network. You may have to adjust access point placement, modify channel assignments, install additional access points or install additional repeaters to improve coverage.
8. **Repeat the WiFi survey if necessary.**
If important changes are made to the network infrastructure or if you want further optimization, do additional surveys to evaluate the effectiveness of the modifications.

To get accurate results use professional tools which are intended for WiFi surveys. We recommend that you consult with a wireless network specialist or professional if you want in-depth analysis or troubleshooting assistance. Take into consideration that the WiFi environment is by nature changing, so it can change during the life cycle of the charging system.

Please see detailed commissioning instructions on <https://evwiki.ensto.technology/>

9. Technical data

Electrical connections	EVB100B-A4BC EVB100B-B4BC	EVB200B-A4BC
Nominal supply voltage *	3-ph, 400 VAC	3-ph, 400 VAC
Charging current (nominal)	3 x 32A	2 x (3 x 32A)
Charging power (nominal)	1 x 22kW	2 x 22kW
Supply connections and terminals	L1, L2, L3, N, PE Cu 2.5 – 16 mm ² (Aluminium not allowed) Recommended 10 mm ² at nominal power Tightening torque: 2,5 Nm	
Grid connections	TN (3-ph) / IT (2-ph, 230Vp-p)	

* Supply voltage range 208 ... 264 V.

Please note that typically electric vehicles do not tolerate more than 7 volts of fluctuation in the main voltage.



Design and mechanics	
Materials	Frame: Powder coated mild steel Cover: Plastic (PETG and ABS)
Color	Frame: RAL7021 "Anthracite" Cover: White and black tape Sticker on the cover: Black
Weight	EVB100B-A4BC : approx. 11 kg EVB100B-B4BC : approx. 12 kg EVB200B-A4BC : approx. 13 kg
Ingress protection rating	IP54
Shock protection rate	IK10
Operating temperature	-25 °C ... +50 °C
Standard	IEC 61851-1:2019, general requirements for electric vehicle conductive charging system
Approvals / markings	CE

User interface	
Socket outlet	Mode 3 / Type 2
Charging status indication	3-color LED <ul style="list-style-type: none"> Green / Ready Blue / Charging Red / Error
Use access	RFID (ISO/IEC 14443A, ISO/IEC 15693, NFC) Free access Mobile apps via 3rd party operators ISO15118 (Plug & Charge support)
Energy measurement	MID class kWh meter

Safety features	EVB100B-A4BC EVB200B-A4BC	EVB100B-B4BC
Protective devices	RCD: At least type A 30mA, must be installed in switchboard	RCBO: residual current circuit breaker and over current protection integrated, type A 30mA, class C, nominal current 32A
	MCB: Max. 32 A, must be installed in switchboard	
	RCD-DD: integrated 6mA DC residual current detection	RCD-DD: integrated 6mA DC residual current detection
	Overvoltage and undervoltage protection (configurable)	
Control voltage	12 VDC	
Temperature control	High operating temperature, such as direct sunlight, can cause reduced charging current or temporary interruption in the charging procedure	

Cybersecurity

- Ensto charging stations are designed to be safe to use according to relevant cybersecurity requirements, where regular security penetration tests are done and all the known vulnerabilities are mitigated.
- The manufacturer provides regular firmware updates. The responsibility to update the charger firmware is under operator/owner/back-office provider.
- The charging stations do not collect personal data and the manufacturer is not liable for personal data, but this is in responsibility of the back-office provider.
- The unique access password of the charging station can be changed. This action must be done during the installation and commissioning to fulfill cybersecurity act (for example EU) requirements. The owner of the charging station must keep the valid passwords safe so that annual maintenance and other activities, which are necessary to keep the charging station in operation, can be done.

Control and communication	
Operation mode	Standalone / Online
Wireless	4G/LTE WiFi 2.4 GHz (IEEE802.11b/g/n) 2 radios (hotspot and client simultaneously)
Wired	LAN / Ethernet
Protocol	OCPP1.5-SOAP or OCPP1.6-JSON
Dynamic Load Management (DLM)	Local, embedded software feature over IP Protocol

10. Code key

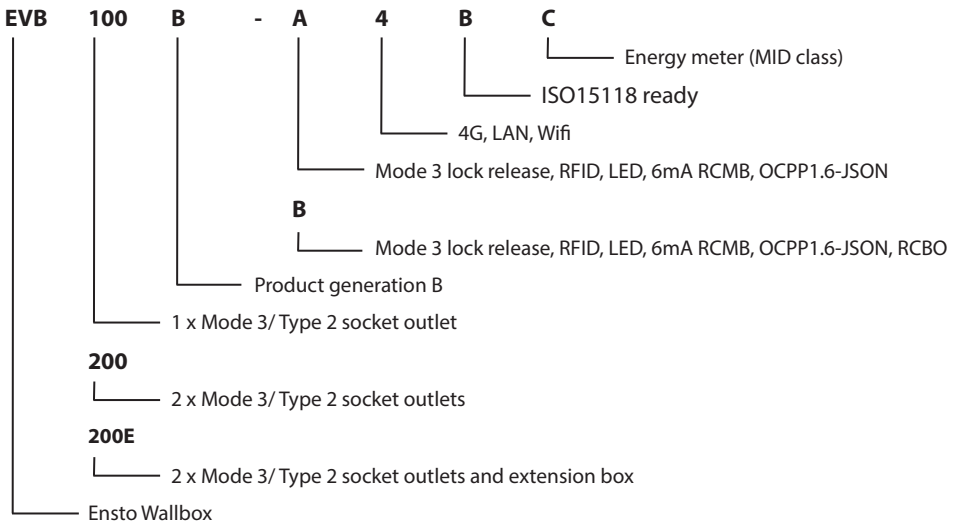

11. Dimensional drawing

EVB100B

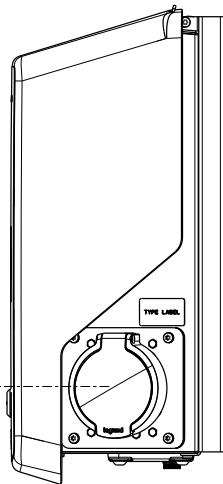
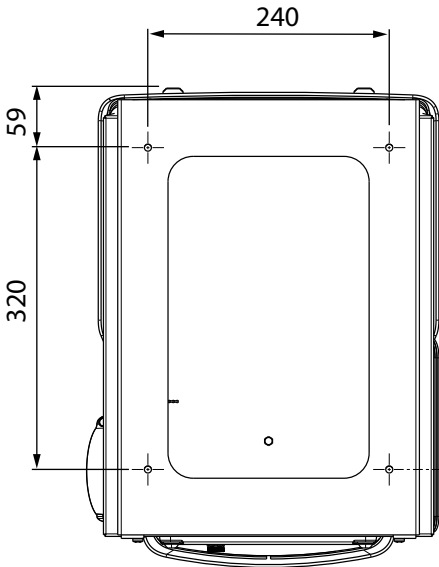
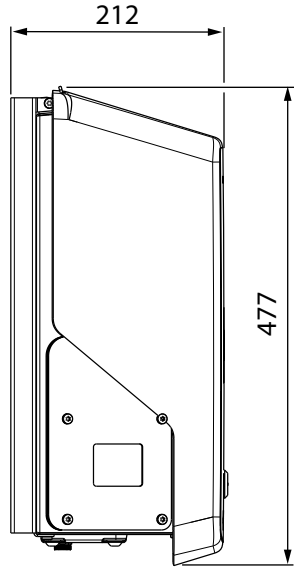
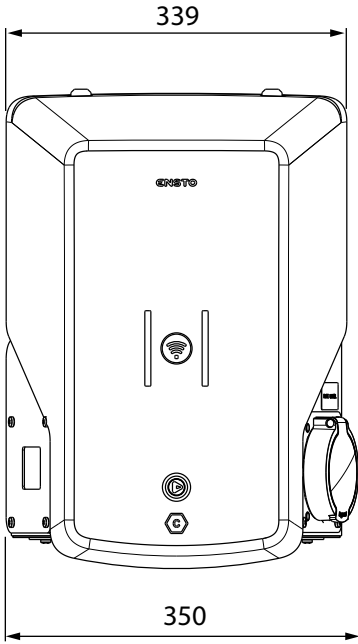

EVB200B

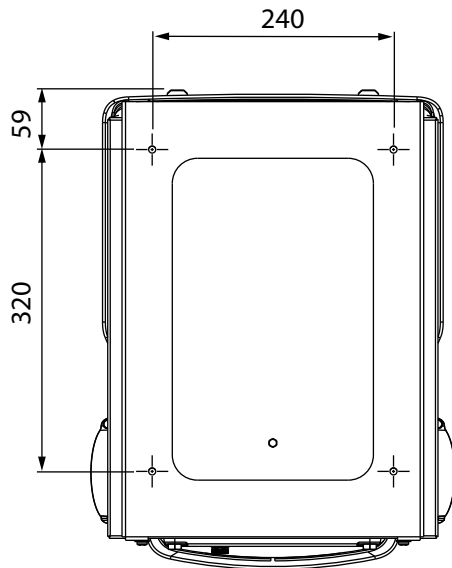
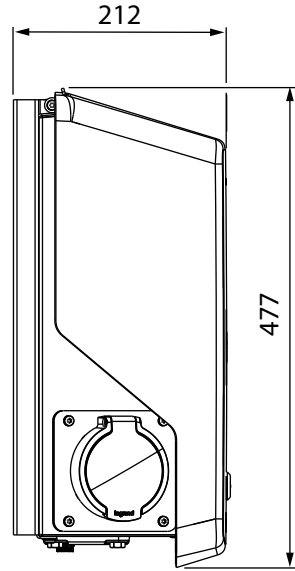
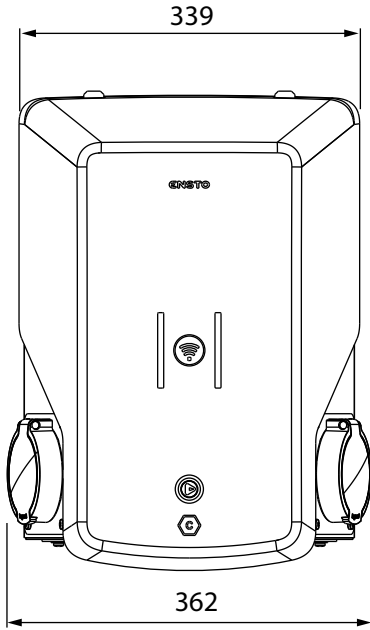

12. Installation / Commissioning checklist

Introduction

Examine the mechanical and electrical installation in accordance with this checklist to make sure that the charging station is properly installed.

Checking the Installation



Examine the visual, mechanical and electrical installation when the charging station is un-powered.

CATEGORY	X	ITEM
Overall look		You have received the ordered material.
		You have removed the protective plastic wrapping.
		You do not see any scratches or damages.
Mechanical installation		The charging station is mounted properly on the installation site.
Electrical installation		The charging station's power supply capacity meets electrical planning (cable size, protective devices...). Review the local electrical design plan.
		The PE-cable screw is tight.
		The power supply conductors (L1, L2, L3, N and PE) are properly connected.
		The insulation of the power supply cable and the conductors (L1, L2, L3, N and PE) is intact.
		The voltage between PE and N is less than 10 V.
Operational check		The PE conductor resistance is less than 3 Ω.
		All the LED states / colors (green, blue, red) and the RFID reader are functioning. <ul style="list-style-type: none"> • Use a car simulator. • Create fail and charge. • Red at bootup, green at idle and blue while charging.
		Test the functionality of the electric protective device. Depending on the charging station model, the device is integrated in the charging station or installed in the switchboard.
Ready for use		The correct SW is in use.
		Correct operating mode <ul style="list-style-type: none"> • Standalone • Online
		Test the data communication, if it is in use. Examine the available signal strength to make sure that the communication (4G, WiFi), reception and connectivity are working.

13. Maintenance / Preventive maintenance instructions

Recommended 1 x per year, take into consideration local regulations and national standards.
Protect the charging station against pollution (water, snow, dust).



WARNING

Danger of electrical shock or injury! Risk of fire!

Disconnect power before working inside the device or removing any components.

X	MAINTENANCE ACTION
	Retighten all the screws on electric components.
	Examine the Mode 3 socket for burn or damaged parts. If necessary, replace it (socket cost is not under warranty).
	Examine the charging cable for wear out and mechanical damage. If necessary, replace it.
	Examine the sealings for wear out. If necessary, replace the sealings.
	All the LED states / color (green, blue, red) are functioning. <ul style="list-style-type: none"> • Use a car simulator. • Create fail and charge. • Red at bootup, green at idle and blue while charging.
	Make sure that the PE-cable screw is tight.
	Test that the voltage between PE and N is less than 10 V.
	Test that the PE conductor resistance is less than 3 Ω.
	Test the surge arrester, if there is any.
	Check if there are software updates available. Update always the latest version released by the charging station manufacturer.
	Restart the charging station from F0. Make sure that it will restart properly.
	Clean possible dirt and dust from the surface of the charging station. Wipe carefully with a moist cloth.
	Examine the visible metal parts for rust. Apply anti-corrosion agent, if necessary.
	Test the functionality of the electric protective device every six months. Depending on the charging station model, the device is integrated in the charging station or installed in the switchboard.

Maintenance actions done by:	Date:
------------------------------	-------



14. Testing instructions for the electric protective device

EVB100B-A4BC / EVB200B-A4BC

Test the residual current device at the supply line.

EVB100B-B4BC

- Press the **TEST** button.
- The rocker turns to **0** position.
- Turn the rocker back to **I** position.
- If a fault occurs, contact an electrician.

15. Troubleshooting

Charging station is off, no lights on

Issue	Corrective action
Mains voltage does not exist in the supply connectors (L1, L2, L3).	Make sure that the supply conductors are properly connected. Make sure that there is power available.
The circuit breaker F0 is off.	Turn the F0 on.
The PWR LED indicator on the controller is not on.	Make sure that power supply to the controller is available.

Charging cable is locked in Mode 3 socket outlet

Issue	Corrective action
Unexpected fault has occurred while the power is on.	Turn off the power from the F0 and pull the charging cable out from the socket.
The power is off.	Open the front cover. Switch the Mode 3 lock into open position.

Configuration via web browser

Issue	Corrective action
The PC does not recognize the USB plug and a connection to the controller cannot be established via web browser.	Make sure from Windows operating system settings via "Device Manager" that RNDIS network adapter is available. If not, contact your local IT support.

16. Warranty

Warranty conditions, see www.ensto.com/building-systems

17. Declaration of Conformity

The EU declaration of conformity is available at the following internet address:

<https://evwiki.ensto.technology/display/CHWI/Certificates>

18. Disposal



Do not dispose of electrical and electronic devices including their accessories with the household waste.









- When the charging station is at the end of its life cycle, it must be disposed of properly according to local recycling guidelines.
- The cardboard packing of the charging station can be recycled.
- Dispose of the plastic wrap with the household waste or according to local recycling guidelines.



User Guide

19. User interfaces

LED indicator lights will show the status of the charging point as described below:

Charging point's status	LED light	LED operation
The charging point is free and ready to use	Green	Stable 
RFID read, authorization ongoing	Green	Flashing 
Charging authorization rejected	Red	Flashing 
Authorization accepted, charging allowed	Green	Waving 
While you connect the charging cable	Green	Flashing twice 
Your vehicle is connected, charging has not started	Green	Waving 
Your vehicle is connected, charging starts	Blue	Waving 
Charging ongoing	Blue	Stable 
Error state	Red	Stable 

20. Charging

20.1. Free charging

Start charging

When the charging point is free and the LED indicator shows green, you can start a charging event.

- 1 Plug the charging cable to your electric vehicle.
Plug the charging cable to the charging point.
The LED indicator turns to stable blue.

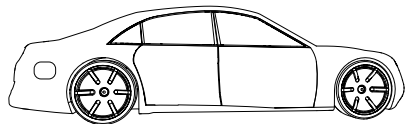
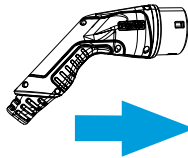

Stop charging

- 2 Unplug the charging cable from the charging point.
Unplug the charging cable from your electric vehicle.
After you have unplugged the charging point is free for the next user.

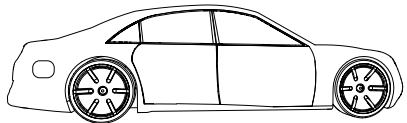
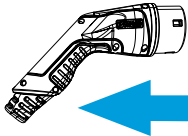

20.2. Charging with RFID

You must have an RFID tag which has a permission to access the charging point.

Start Charging with RFID

- 1 Plug the charging cable to your electric vehicle.
Plug the charging cable to the charging point.

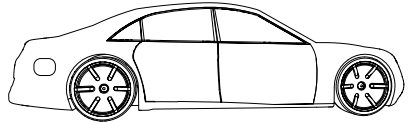
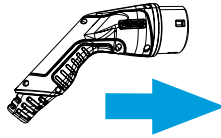

- 2 Show the RFID tag to the RFID reading area.
While the RFID tag is read, the LED indicator flashes green and verifies the user permission to charge.



- If the user authorization is rejected, the LED indicator flashes red.
- If the user authorization is accepted, the indicator light turns to waving green.

- 3 Charging event starts.
 - The LED indicator turns to stable blue.

Stop Charging with RFID



- 4 Show the RFID tag to the RFID reading area.
Charging event ends.

- The LED indicator turns to waving green.

- 5 Unplug the charging cable from the charging point.
Unplug the charging cable from your electric vehicle.

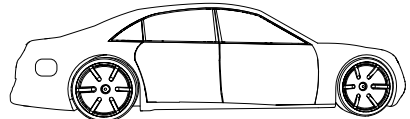
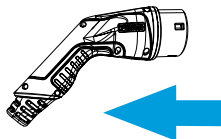

Ensto Chago Oy
Ensio Miettisen katu 2, P.O. Box 77
FIN-06101 Porvoo, Finland
Tel. +358 204 76 21
www.ensto.com/building-systems

ENSTO

Ensto Building Systems

A brand of  **legrand**